

DNA1425T-DNA1525T

Thermal Bullet Cameras



Installation and Operations Manual

Model Number: DNA1425T, DNA1525T

Description: Thermal Bullet Cameras

with Intelligent Analytics

Thermal Imaging Fixed Network Camera

Quick Start Guide

Version 1.0.1

Welcome

Thank you for purchasing our network camera!

This quick start guide is designed to be a reference tool for your system.

Please keep this start guide well for future reference.

Please open the accessory bag to check the items one by one in accordance with the list below.

Contact your local retailer ASAP if something is missing or damaged in the bag.

Important Safeguards and Warnings

1 . Electrical safety

All installation and operation here should conform to your local electrical safety codes.

Please check if the power supply is correct before operating the device.

The power shall conform to the requirement in the SELV (Safety Extra Low Voltage) and the Limited power source is rated 12VDC, 5VDC or 24VAC in the IEC60950-1. (Power supply requirement is subject to the device label).

Please install easy-to-use device for power off before installing wiring, which is for emergent power off when necessary.

Please prevent the line cord from being trampled or pressed, especially the plug, power socket and the junction from the device.

Note: Do not connect these two power supplying sources to the device at the same time; it may result in device damage!

We assume no liability or responsibility for all the fires or electrical shock caused by improper handling or installation.

We are not liable for any problems caused by unauthorized modification or attempted repair.

2 . Environment

- Avoid aiming the lens at the strong radiation source directly (such as sun, laser, molten steel etc); in case it may cause unrecoverable damage to the thermal imaging detector. What's worse, it may cause severe damage to the detector.
- Avoid oil stain and kinds of chemicals tarnishing and damaging the lens surface.
- Store the device in a cool and dry place where there is ventilation but no intense electromagnetic field.
- Violent vibration or crash is not allowed during transportation and application.
- Please transport, use and store the device within the range of allowed humidity and temperature.
- Please don't keep the device in a place which is wet, dusty, extremely hot, and extremely cold and with strong electromagnetic radiation or unstable lighting.
- Please do not allow water and other liquid falling into the camera in case that the internal components are damaged.
- Please do not allow rain or damp to the indoor device in case fire or lightning may occur.
- Please keep the sound ventilation in case of heat accumulation.
- Please pack the device with standard factory packaging or material with same quality when transporting the device.

Heavy stress, violent vibration or water splash are not allowed during transportation, storage and installation.

3. Operation and Daily Maintenance

Please do not touch the heat dissipation component of the device directly in order to avoid scald.

Please do not dismantle the device; there is no component which can be fixed by users themselves in the machine. It may cause water leakage or bad image for the device due to unprofessional dismantling. It is recommended to use the device with thunder proof device in order to improve thunder proof effect. The grounding holes of the product are recommended to be grounded to further enhance the reliability of the camera.

Do not touch the CCD (CMOS) optic component directly. User may use the blower to clean the dust or dirt on the lens surface. Please use a dry cloth wetted by alcohol to wipe away the dust gently if it is necessary to clean.

Always use the dry soft cloth to clean the device. If there is too much dust, please use the water to dilute the mild detergent first and then use it to clean the device. Finally use the dry cloth to clean the device. Don't use volatile solvent like alcohol, benzene, thinner and etc or strong detergent with abrasiveness, otherwise it will damage the surface coating or reduce the working performance of the device.

Dome cover is an optical device, please don't touch or wipe cover surface directly during installation and use, please refer to the following methods to deal with once dirt is found:

Stained with dirt

Use oil-free soft brush or hair dries to remove it gently.

Stained with grease or fingerprint

Use soft cloth to wipe the water drop or oil gently to make it dry, then use oil-free cotton cloth or paper soaked with alcohol or detergent to wipe from the lens center to outward. It is ok to change the cloth and wipe several times if it is not clean enough.

Warning

Please use the standard accessories provided by manufacturer and make sure the device is installed and fixed by professional engineers.

Please prevent the device surface from the radiation of laser beam when using laser beam device.

Please do not provide two or more power supply modes for the device, otherwise it may cause damage to the device.

Statement

Please refer to the actual product for more details; the manual is just for reference.

The manual will be regularly upgraded according to the product update; the upgraded content will be added in the manual without prior announcement.

Please contact the supplier or customer service if there is any problem occurred when using the device.

Please contact the customer service for the latest procedure and supplementary documentation.

There may be deviation between the actual value of some data and the value provided in the manual due to the reasons such as the real environment is not stable and so on. Please refer to the company's final explanation if there is any doubt or dispute.

The company is not liable for any loss caused by the operation which is not followed by the manual.

Note:

Please refer to the disk for more details, check and download corresponding user's manual and tool.

Before installation, please open the package and check all the components are included.

Contact your local retailer ASAP if something is broken in your package.

Accessory Name	Amount
Network Camera Unit	1
Quick Start Guide	1
Installation Accessories Bag	1
CD	1

Table of Contents

1	Device Structure	1
1.1	Device External Cable	1
1.2	Framework and Dimension	2
1.3	Alarm Setup.....	3
2	Device Installation	6
2.1	Install Device	6
3	Network Configuration	9
3.1	Modify IP Address	9
3.2	Login WEB Interface	11

1 Device Structure

1.1 Device External Cable

Note:

The following figure of structure is for reference only; it is used to know the function of cable ports. Different models may have different cable structures, please refer to the actual product for exact details.

User may refer to the following figure for device external cable information. See Figure 1-1.

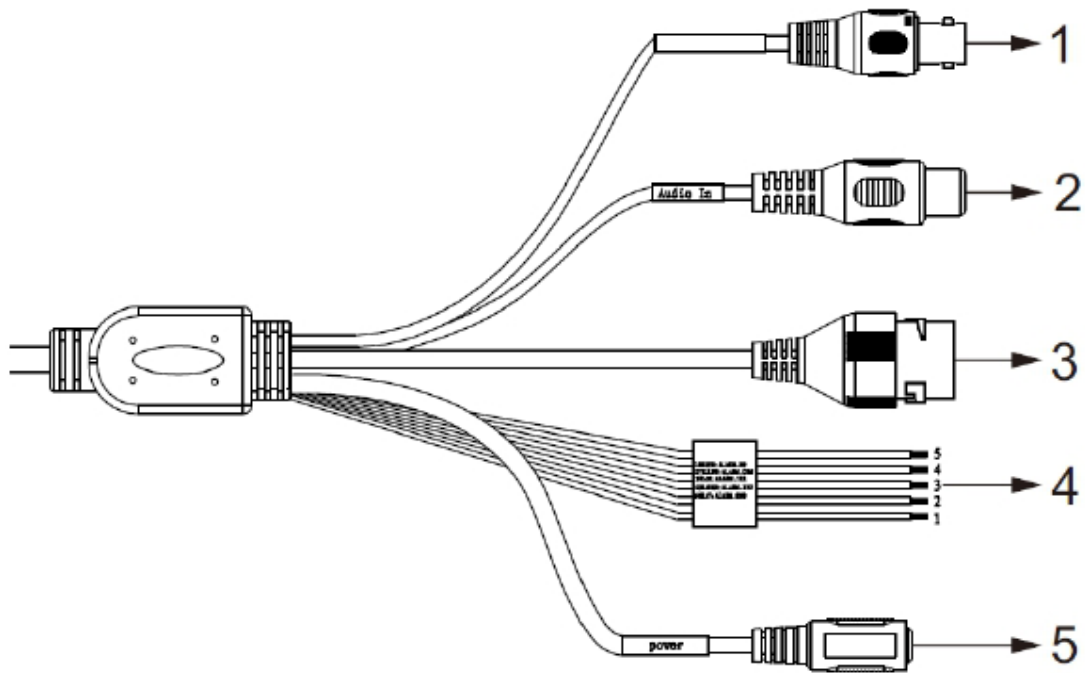

Figure 1-1

Please refer to the following sheet for detailed information.

SN	Port	Port Name	Connector	Function Description
1	VIDEO OUT	Video output port	BNC	Output analog video signal, able to connect TV monitor to view image.
2	AUDIO IN	Audio input port	RCA	Input audio signal, receive the analog audio signal from the pickup and etc.
3	LAN	Network port	Ethernet port	Connect to standard Ethernet cable. Note: Some series products don't support PoE.
4	I/O	I/O port	-	Alarm signal input/output
5	Power	Power input port	-	Power port. Input DC 12V or AC24V. Note: Input AC 24V, default DC5.5 round port to 2 pin converter cable. Actual use in accordance with device label instruction.

Please refer to the follow sheet for detailed pin information.

Port Name	SN	Name	Function Description
I/O Port	1	ALARM_COM	Alarm output public port
	2	ALARM_NO	Alarm output port, output alarm signal to alarm device. NO: normally open alarm output port
	3	ALARM_IN1	Alarm input port 1; It is to receive the on-off signal from the external alarm source.
	4	ALARM_IN2	Alarm input port 2; It is to receive the on-off signal from the external alarm source.
	5	GND	Ground port

Note:

Use the loop back head in the accessories bag and insert it into the network port before the device power on, then power on the device, at this moment BNC outputs HDCVI signal.

1.2 Framework and Dimension

Note:

The following figures are for reference only, which is used to know the device dimension. Please refer to the actual product for exact details.

Please refer to the following two figures for dimension information. The unit is mm. See Figure 1-2 to Figure 1-4.

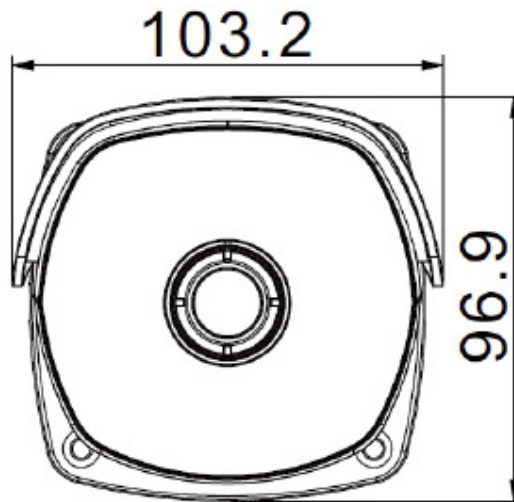

Figure 1-2

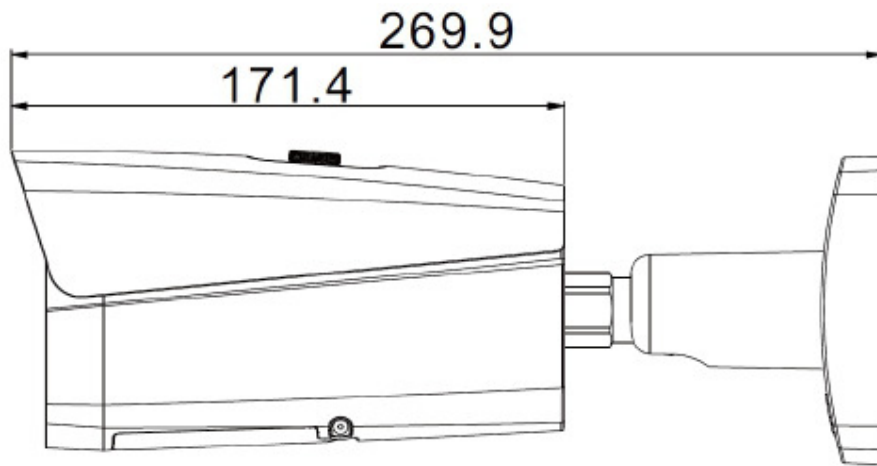

Figure 1-3

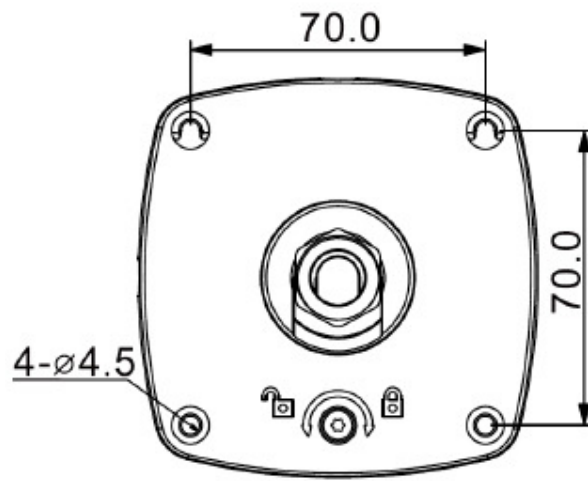

Figure 1-4

1.3 Alarm Setup

Note: Some products do not support alarm function, which cannot be applied to this chapter. The alarm interface is shown as in Figure 1-5.

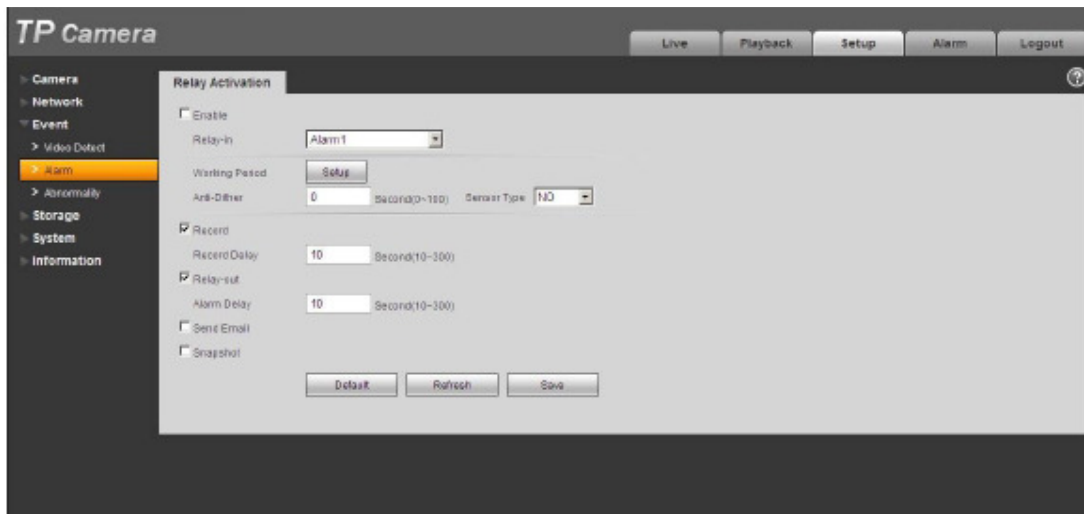

Figure 1-5 Alarm

Alarm input, output connection description:

- Step 1 Connect alarm input device to the alarm input of I/O cable.
- Step 2 Connect alarm output device to the alarm output of I/O cable, alarm output is collector open circuit output which connects 10K resistor to 3.3V externally.
- Step 3 Open the Web, set alarm input and output correspondingly. Alarm input on WEB corresponds to I/O cable on device. When there is alarm, alarm input device will generate signal of high and low level. Set corresponding NO and NC inputs.
- Step 4 Set the WEB alarm output. The alarm output is for the alarm output port of the device. It is the alarm output port of the I/O cable.

Please refer to the following figure for alarm input information. See Figure 1-6.

Alarm input: When the input signal is idle or grounded, the device can collect the different statuses of the alarm input port. When the input signal is connected to 3.3V or it is idle, the device collects the logic "1". When the input signal is grounded, the device collects the logic "0".

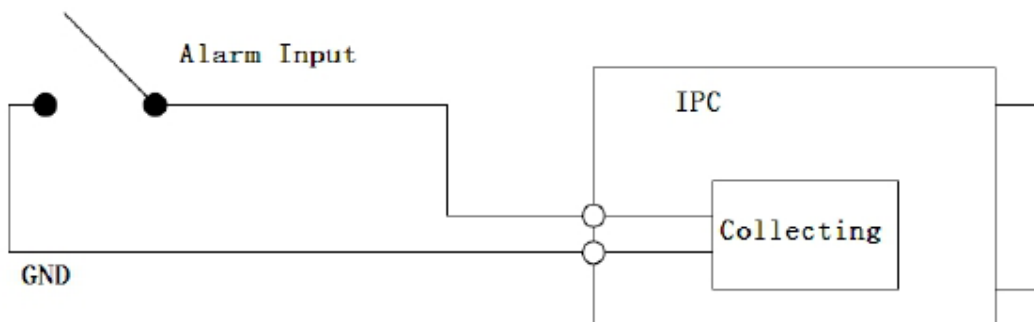

Figure 1-6

Please refer to the following figure for alarm output information. See Figure 1-7.

When alarm output is OC, it needs to increase pull-up resistance externally to work normally; output signal is high and low level. After external pull-up resistance is increased, the default of output signal is high level, and it switches to low level when there is alarm output.

The working current of alarm output port is recommended as $\leq 10\text{mA}$. The max current which is used to drive external circuit is 80mA , it is advised to add a relay if it is beyond the value.

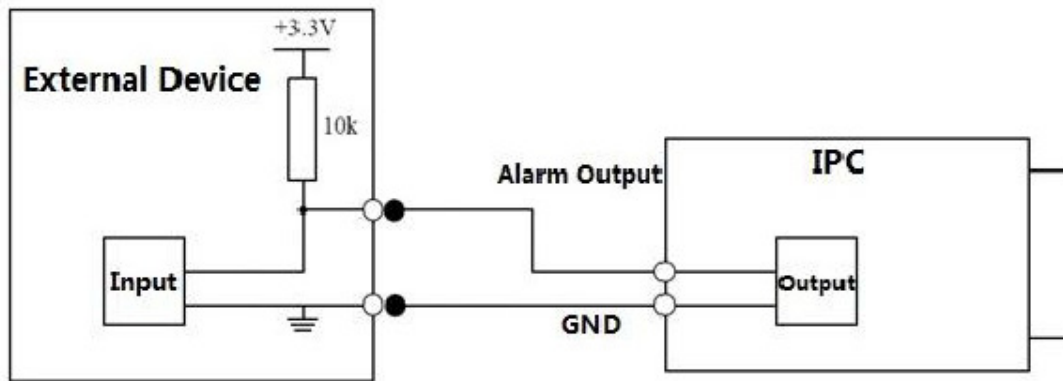

Figure 1-7

2 Device Installation

2.1 Install Device

The device can adopt wall mount installation and pendant installation

Please follow the steps listed below to install the device. Please refer to Figure 2-1 for reference.

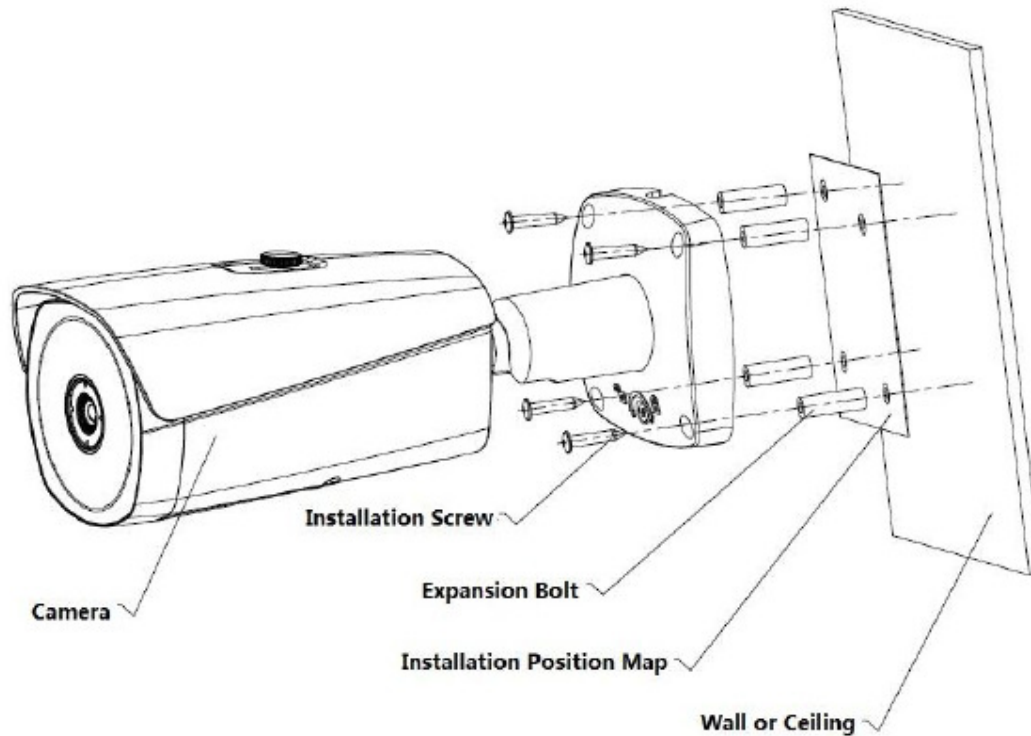

Figure 2-1

Warning:

The installation surface must min sustain the 3X weight of camera to prevent it from falling. Please avoid the device, part, tool and etc. falling during installation in case it will damage the device, lack parts and injure passers-by and other objects.

Step 1

Select a smooth installation surface (wall or ceiling and etc.), and make sure the installation surface can sustain the weight of the device, then stick the installation position map on the proper location according to the requirements.

Step 2

Dig holes according to the four installation holes marked on the installation position map, pay attention that the pore size and depth have to be matched with expansion bolts, the deviation of pore size is not allowed.

Step 3

Open the accessories bag and take out the expansion screws, then insert the expansion screw into the hole you just dug with a hammer, keep the outer end and the installation surface parallel.

Step 4

Open the accessories bag and take out the installation screws. Aim four installation holes on the camera bracket at the four installation holes on the expansion screws, make the installation screws go through the bracket holes and insert them into the installation holes of the expansion screws, tighten the four installation screws and fix the device on the installation surface firmly (wall or ceiling);

Step 5

Plug external cable of the device properly according to the requirements; please notice that the power adapter should be consistent with the camera power.

Attention:

All the external cable connectors need waterproof processing if they are exposed to outdoor environment.

Figure 2-2

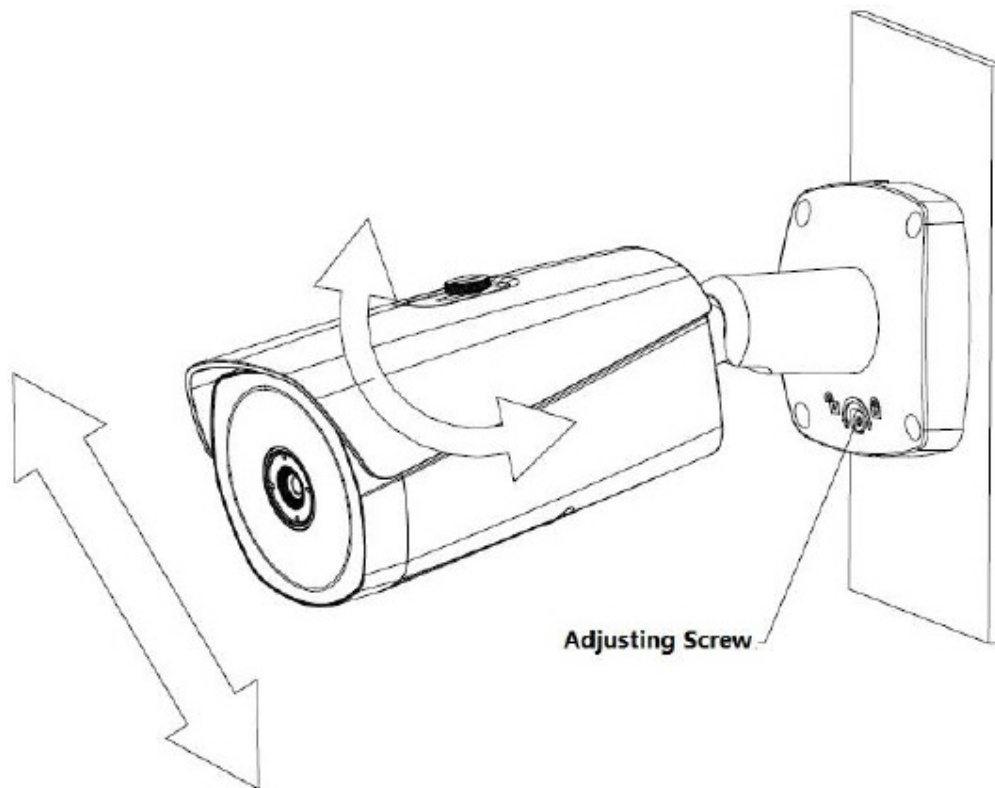
**Attention:**

Please be sure to loosen the adjusting screw when adjusting the device position and angle, tighten the adjusting screw after adjustment.

Please do not rotate the camera body over 360° when the camera body and the installation chassis form an angle of 90° and the adjusting screw is fixed firmly.

Step 6

Open the accessories bag and take out the inner hex wrench to loosen the adjusting screw, adjust the front-end device in all possible directions (up and down, left and right) and make sure rotation adjustment is less than 360° according to the monitoring direction; Use inner hex

wrench to tighten the adjusting screw and make sure the bracket can't be rotated after meeting the monitoring requirements.

Step 7

User may move the sunshade cover back and forth and adjust it according to the application scene; you need to tighten the fastening screw on the sunshade cover after adjustment.

3 Network Configuration

The IP address of all the cameras is the same when leaving factory (default IP192.168.1.108), in order to make the camera get access to the network smoothly, please plan the useable IP segment reasonably according to the actual network environment.

3.1 Modify IP Address

IP address can be acquired and modified through quick configuration tool for the cameras which are accessed via wired network, it needs to connect wired network to configure wireless parameters before using wireless network cameras. In this chapter, it will introduce the approach of modifying IP address via “Quick Configuration Tool”; also user may modify the IP address in the network parameters of the WEB interface, please refer to the document in the disk << WEB Operation Manual>> for more details.

Note:

Currently the quick configuration tool only supports the cameras which apply to the same network segment with computer IP address.

Step 1 Double click the “ConfigTools.exe” and open the quick configuration tool.

Step 2 Double click the device to be configured, the system will pop out the “Login” dialog box.

Enter the IP address, user name, password and port number of the camera, and click “Confirm”.

Note:

The default user name and password are admin and admin respectively, the default of port is 37777. See Figure 3-1 for more details.

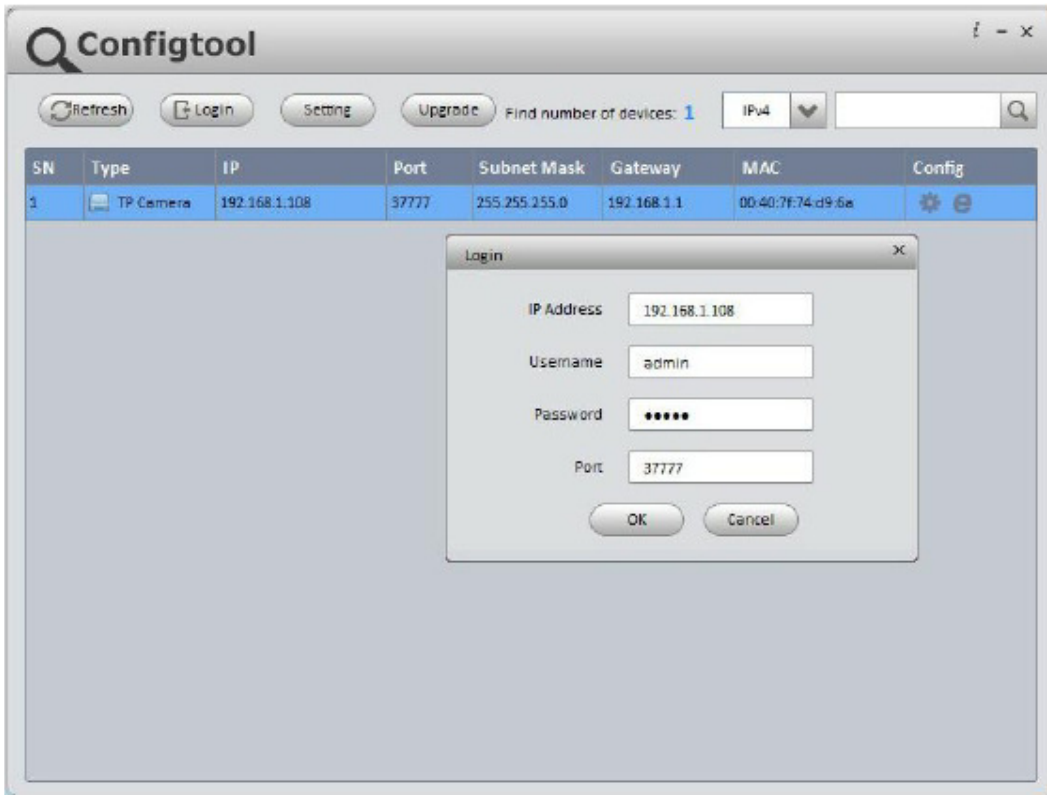

Figure 3-1

Step 3 Modify the camera IP address on the “Net” interface, click “Save” to finish modification. See Figure 3-2 for more details.

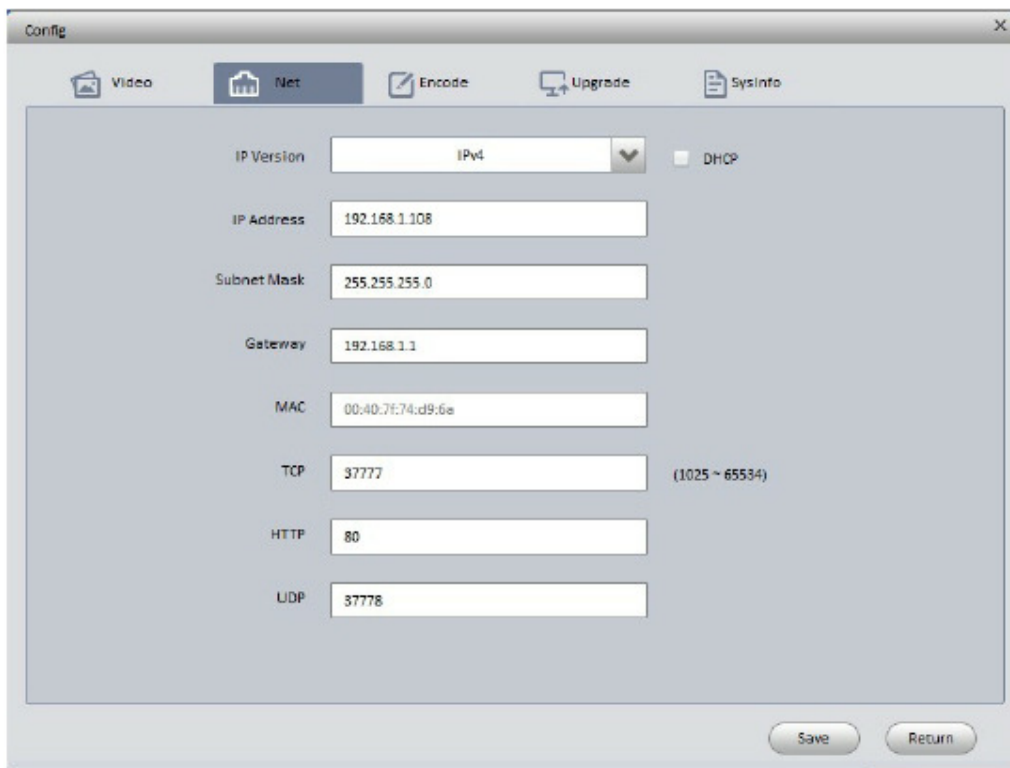

Figure 3-2

3.2 Login WEB Interface

Note:

Different devices may have different WEB interfaces, the figures below are just for reference, please refer to the document <<WEB Operation Manual>> in the disk and the actual interface for more details

Step 1 Open IE and input the modified camera IP address in the address bar.

Step 2 The login interface is shown below, please input your user name and password (Default user name is admin and password is admin respectively), click “login”.

See Figure 3-3 for more details.



Figure 3-3

Step 3 Install controls according to the system prompt; see Figure 3-4 for the WEB main interface.

Please modify the administrator password as soon as possible after you successfully logged in.

Figure 3-4

Note:

- **This quick start guide is for reference only. Slight difference may be found in user interface.**
- **All the designs and software here are subject to change without prior written notice.**
- **If there is any uncertainty or controversy, please refer to the final explanation of us.**
- **Please visit our website or contact your local service engineer for more information.**

For Technical support write to:

support@dantesecurity.net

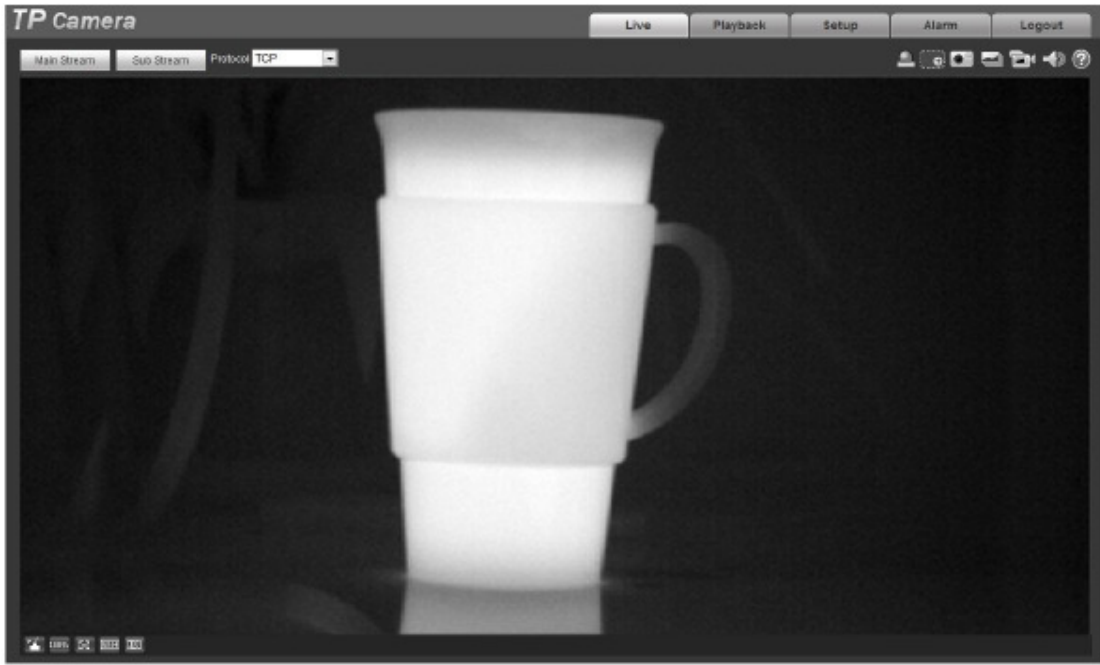

Table of Contents

1	Network Config	1
1.1	Network Connection	1
1.2	Log in	1
2	Live	6
2.1	Encode Setup	6
2.2	System Menu	7
2.3	Video Window Function Option	7
2.4	Video Window Setup	8
2.4.1	Image Adjustment.....	8
2.4.2	Original Size	9
2.4.3	Full Screen	9
2.4.4	Width and Height Ratio	9
2.4.5	Fluency Adjustment.....	9
2.4.6	Rules Info	9
2.4.7	Realtime Report	9
2.4.8	Ray Axis Correct	10
3	Playback	11
3.1	Playback	11
3.1.1	Function of Play.....	12
3.1.2	Playback File	12
3.1.3	Playback Cut	15
3.1.4	Record Type	15
3.1.5	Progress Bar.....	15
3.1.6	Assistant Function	16
3.2	Picture Playback	16
3.2.1	Play	17
3.2.2	Playback File	17
3.2.3	Snapshot Type	19
4	Report	21
5	Setup	23
5.1	Camera	23
5.1.1	Conditions.....	23
5.1.2	Video	26
5.1.3	Audio	33
5.2	Network.....	34
5.2.1	TCP/IP	34
5.2.2	Connection	35

5.2.2.1	Connection	35
5.2.3	PPPoE	38
5.2.4	DDNS	39
5.2.5	IP filter	39
5.2.6	SMTP (e-mail)	40
5.2.7	UPnP	41
5.2.8	SNMP	42
5.2.9	Bonjour	45
5.2.10	Multicast	45
5.2.11	802.1x	46
5.2.12	QoS	47
5.3	Event	48
5.3.1	Video detect	48
5.3.2	IVS Analyse.....	52
5.3.3	Temperature Alarm.....	59
5.3.4	Fire Alarm.....	60
5.3.5	Alarm	63
5.3.6	Abnormity.....	64
5.4	Temperature	67
5.4.1	Rule Setup.....	67
5.4.2	Global	71
5.4.3	Heatmap	76
5.5	Storage Management.....	76
5.5.1	Schedule.....	76
5.5.2	Destination	80
5.5.3	Record control	82
5.6	System	83
5.6.1	General.....	83
5.6.2	Account.....	85
5.6.3	Default	89
5.6.4	Import/Export	89
5.6.5	Auto Maintenance.....	89
5.6.6	Upgrade	90
5.7	Information	91
5.7.1	Version.....	91
5.7.2	Log	91
5.7.3	Online User	92
6	Alarm	93
7	Log out	95

Important

The following functions are for reference only. Some series products may not support all the functions listed below.

1 Network Config

1.1 Network Connection

Network camera and PC connection mainly has two ways, see Figure 1-1 and Figure 1-2.



Figure 1-1

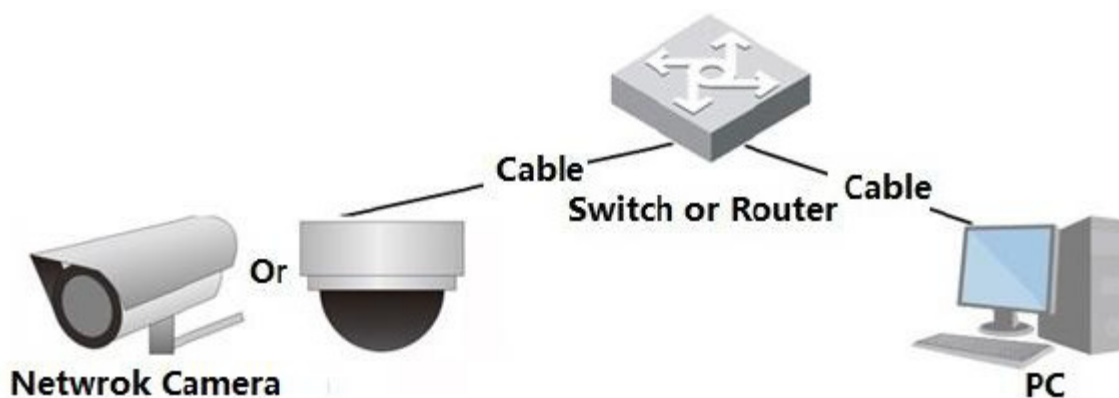

Figure 1-2

Before user access network camera via the Internet, user needs to have its IP address. User can use quick config tool to search IP of the network camera. Please refer to Quick Configuration Tool manual.

1.2 Log in

Open IE and input network camera address in the address bar.

For example, if user camera IP is 192.168.1.108, then please input `http:// 192.168.1.108` in IE address bar.

The login interface is shown as below. See Figure 1-3.

Please input user name and password.

Default factory username is **admin** and password is **admin**.

Note: For security reasons, please modify user password after user first login.

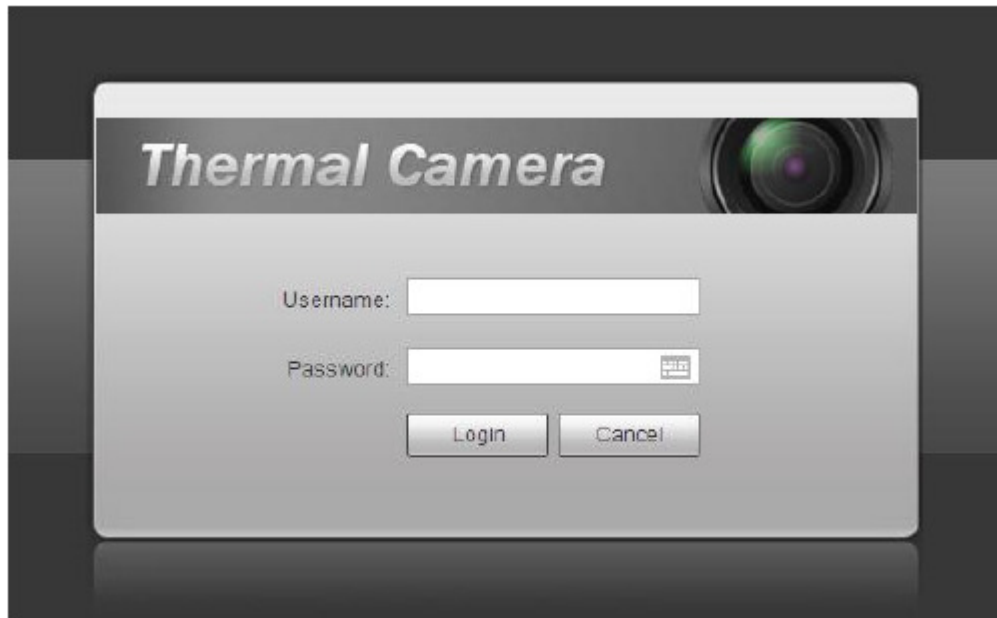

Figure 1-3

If it is user first time to login in, user may see the interface shown as in Figure 1-4.

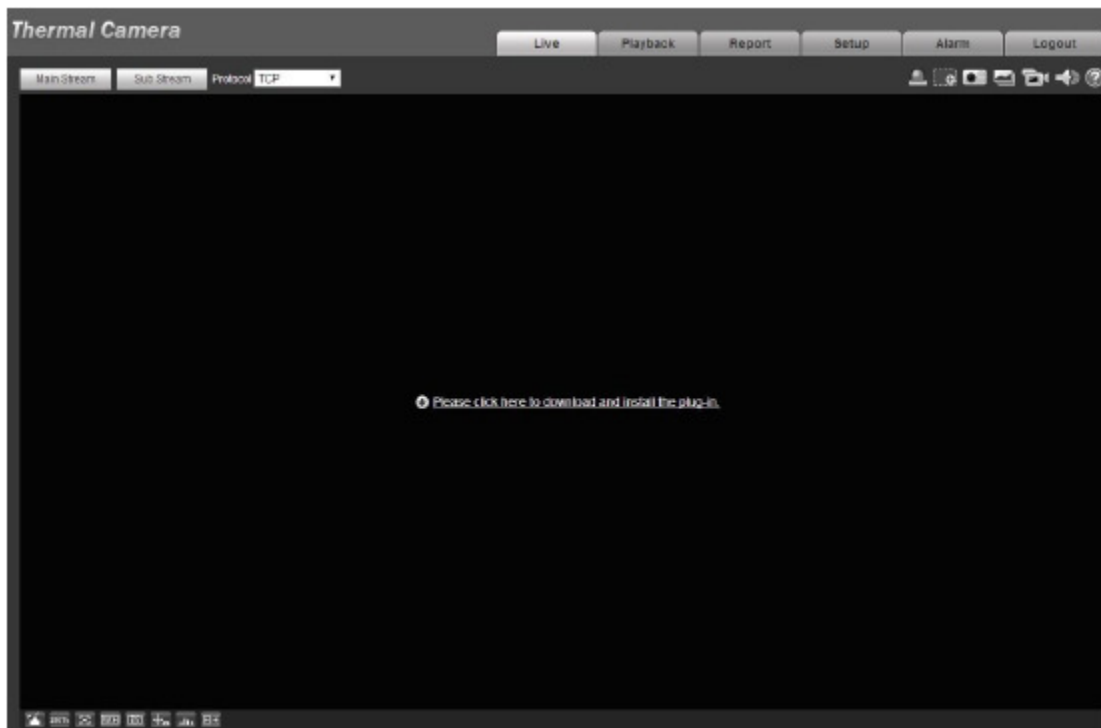

Figure 1-4

Click on “Please click here to download and install the plug-in”. The system pops up warning information to ask user whether run or save this plug-in. See Figure 1-5.



Figure 1-5

User must either run or save the file to local and install it. Follow the following steps. Click on run, user will see Figure 1-6 and Figure 1-7.

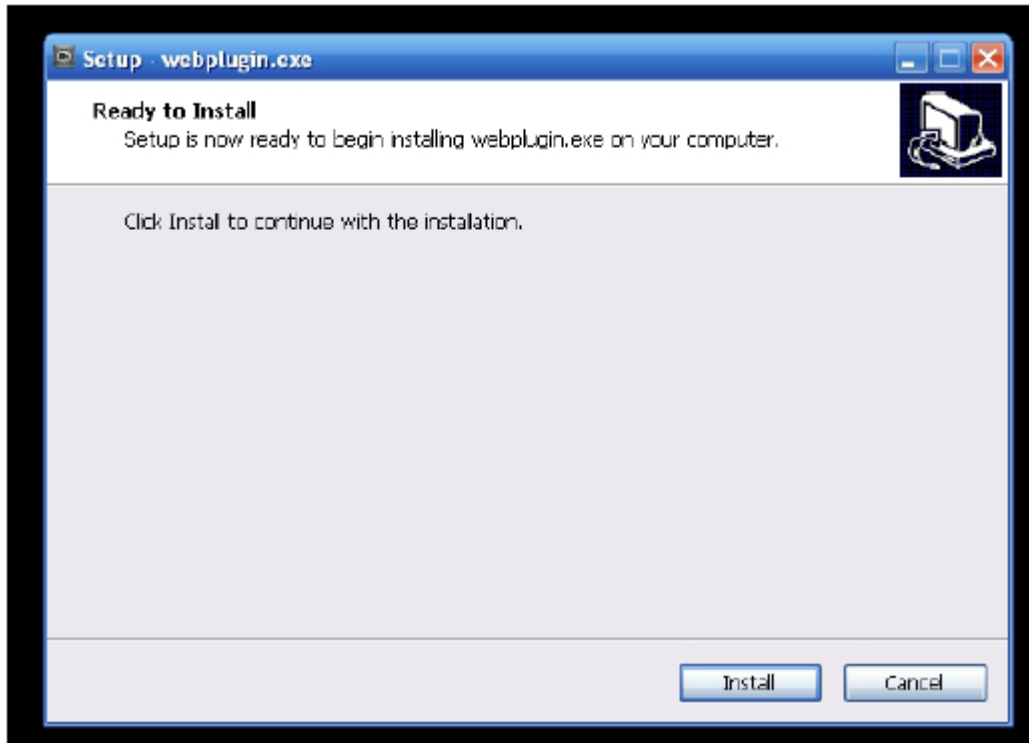

Figure 1-6

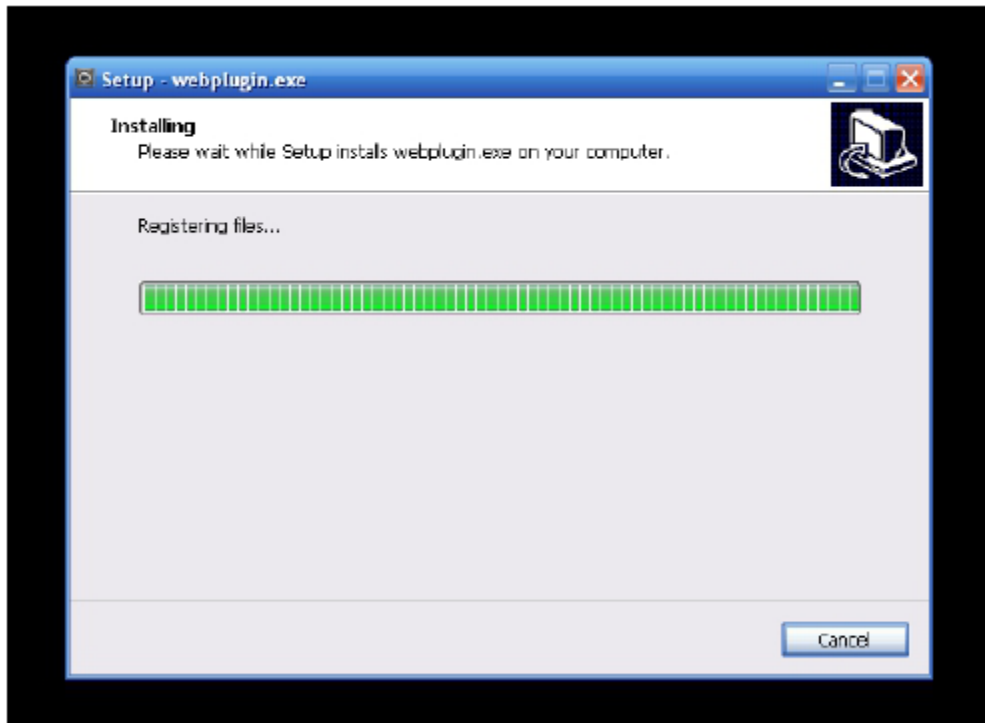

Figure 1-7

When plug-in installation completes, the installation page closes automatically. The web-end will refresh automatically, and then user may view video captured by the camera. See Figure 1-8.



Figure 1-8

2 Live

After user logged in, user may see the live monitor window. See Figure 2-1.



Figure 2-1

There are four sections:

- Section 1: Encode setup bar
- Section 2: System menu
- Section 3: Window function option bar
- Section 4: Window adjust bar

2.1 Encode Setup

The encode setup interface is shown as in Figure 2-2.

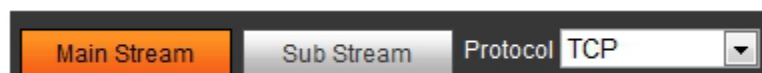

Figure 2-2

Please refer to the following sheet for detailed information.

Parameter	Function
Main stream	Streaming media protocol connection, under main stream config, monitor video or not. Generally for storage and monitor.
Sub (Extra) stream	Streaming media protocol connection, under sub stream config, monitor video or not. When network bandwidth is insufficient, it substitutes main stream for monitoring.
Protocol	User may select stream media protocol from the dropdown list. There are three options: TCP/UDP/Multicast

2.2 System Menu

System menu is shown as in Figure 2-3.

Please refer to chapter 2 Live, chapter 3 Playback, chapter 4 Setup, chapter 5 Alarm, chapter 6 Log out, for detailed information.



Figure 2-3

2.3 Video Window Function Option

The interface is shown as below. See Figure 2-4.

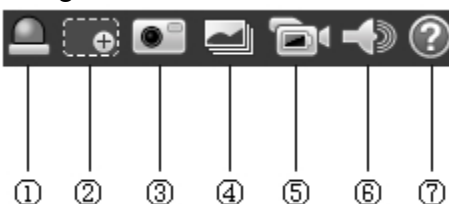

Figure 2-4

Please refer to the following sheet for detailed information.

SN	Parameter	Function
1	Alarm output	It shows if there is any alarm output, status description is as follows: <ul style="list-style-type: none"> ● Red: means there is alarm output. ● Grey: means alarm is over. Click on the button to force alarm to be on or off.
2	Zoom in	<ul style="list-style-type: none"> ● When the video is in the original status, click it user may select any zone to zoom in. In the non-original status, user may drag the zoom-in zone in specified range. Right click mouse to restore previous status. ● Click it; user may use the middle button of the mouse to zoom in/out the video size.

3	Snapshot	Click on the button to snapshot, save picture to path in Ch 5.1.2.5.
4	Triple snap	Click it, system can snap at 1f/s. All images are saved to path in Ch 5.1.2.5.
5	Record	Click it, system can record. All images are saved to path in Ch 5.1.2.5.
6	Audio output	Turn on or off audio when user are monitoring. Note: Only supported by the device with audio.
7	Help	Click it to open help file.

2.4 Video Window Setup

The interface is shown as in Figure 2-5.

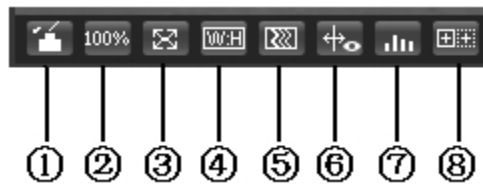

Figure 2-5

2.4.1 Image Adjustment

See Figure 2-6 for image adjustment.

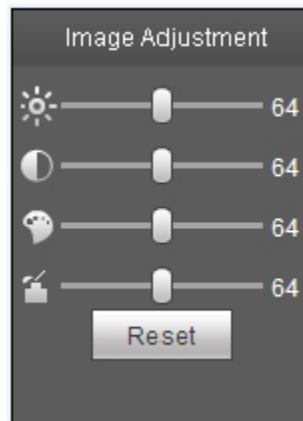

Figure 2-6

Click this button to display/hide image control interface. Click it to open picture setup interface. This interface is on the top right pane.

Please refer to the following sheet for detailed information.

Parameter		Function	
Video setup		It is to adjust monitor video brightness.	Note: ● All the operations here apply to WEB end only. ● Please go to Setup->Camera->Conditions to adjust corresponding items.
		It is to adjust monitor video contrast.	
		It is to adjust monitor video hue.	
		It is to adjust monitor video saturation.	
	Reset	Restore brightness, contrast saturation and hue to system default setup.	

2.4.2 Original Size

Click this button to go to original size. It is to display the actual size of the video stream. It depends on the resolution of the bit stream.

2.4.3 Full Screen

Click it to go to full-screen mode. Double click the mouse or click the Esc button to exit the full screen.

2.4.4 Width and Height Ratio

Click it to restore original ratio or suitable window.

2.4.5 Fluency Adjustment

There are three levels of fluency for user to select (real-time, normal, fluent). The default is normal.

2.4.6 Rules Info

Click it to enable preview page to display intelligent rules, the default is on.

Note:

The function is only supported by some devices.

2.4.7 Realtime Report

It is to open or close temperature record interface, it mainly records the temperature change of selected spot, line and area within designated time period starting from the current time. See Figure 2-7.

Note:

The function is only supported by some devices.

2.4.8 Ray Axis Correct

It is to enable or disable ray axis correct.

Note:

The function is only supported by some devices.

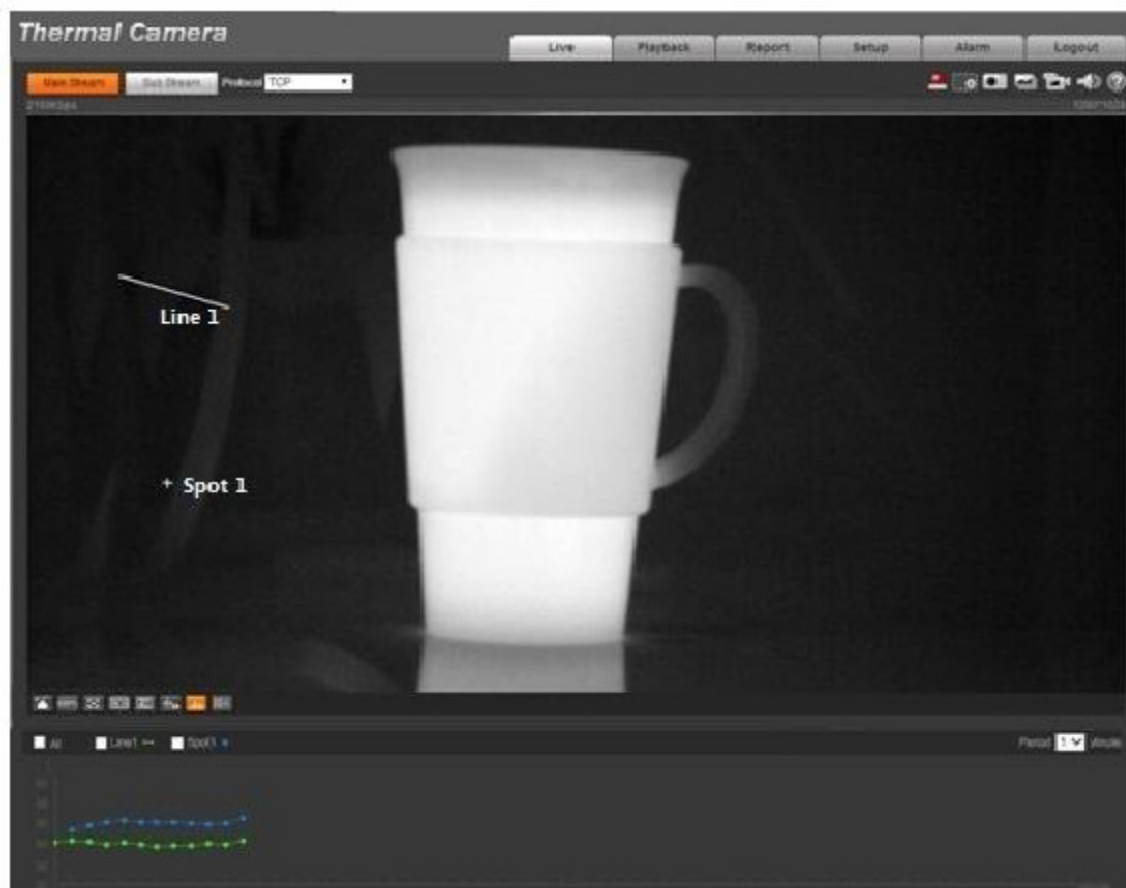

Figure 2-7

3 Playback

Web client playback supports video playback and picture playback.

Note:

Before playback, user shall set storage management as in Ch 5.5.

3.1 Playback

The playback interface is shown as in Figure 3-1.

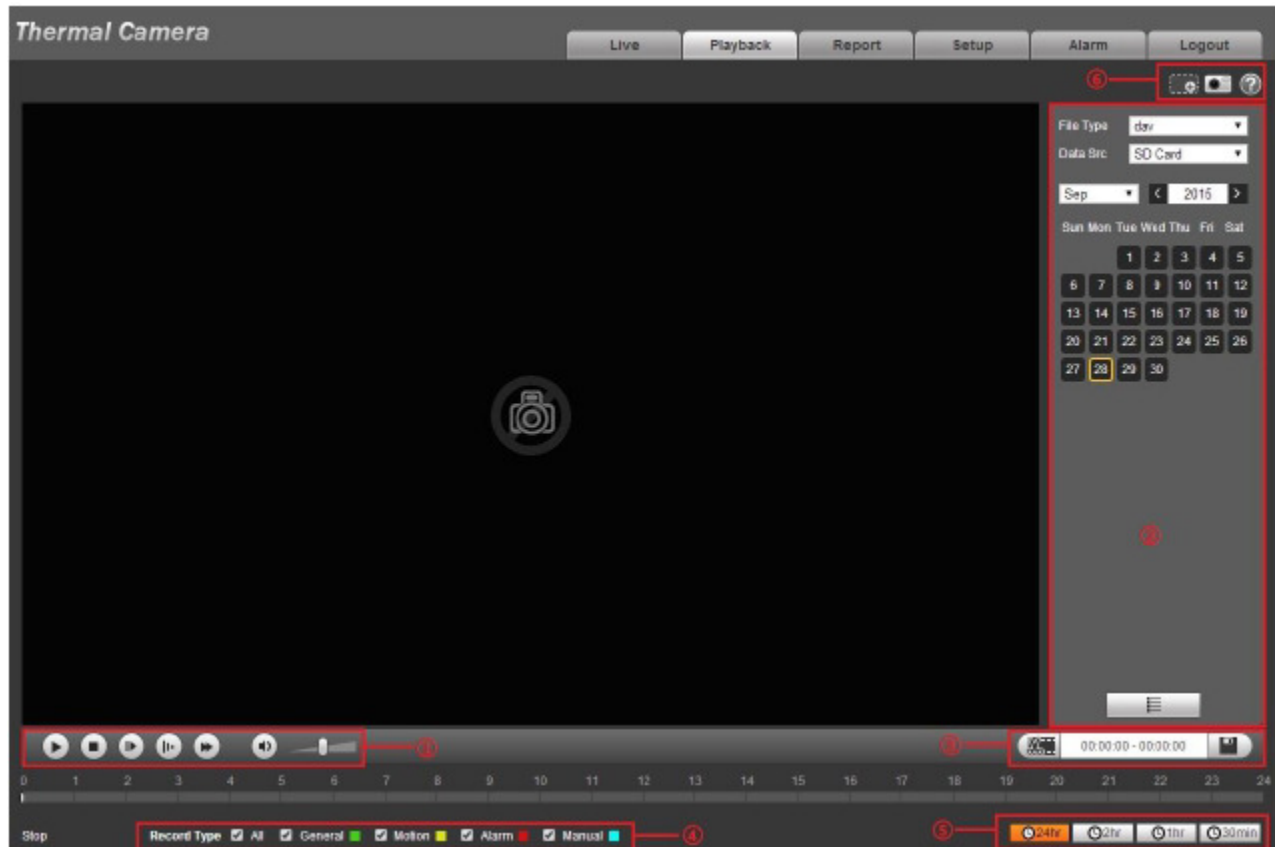

Figure 3-1

There are four sections:

- Section 1: Function of play
- Section 2: Playback file
- Section 3: Play time cut
- Section 4: Record type
- Section 5: Progress bar
- Section 6: Assistant function

3.1.1 Function of Play

The function of play is shown as in Figure 3-2.

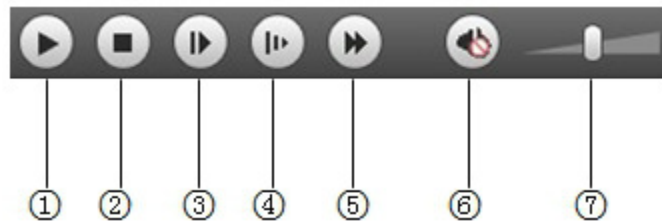

Figure 3-2

Parameter	Function
① Play	When user see this button, it means pause or not played record. Click on this button, switch to normal play status.
② Stop	Click this button to stop playing.
③ Play by frame	Click on this button to go to next frame. Note: User shall pause record when user use this function.
④ Slow	Click on this button to play slowly.
⑤ Quick	Click on this button to play quickly.
⑥ Silent	When this button displays, it means audio is silent. Click on this button to switch back to normal.
⑦ Volume	Click on left mouse to adjust volume.

3.1.2 Playback File

In calendar, blue date represents data currently has video record or snapshot. See Figure 3-3.

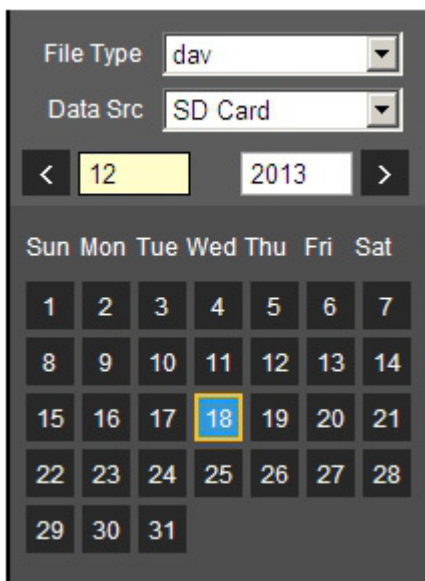

Figure 3-3

Parameter	Function
File Type	<ul style="list-style-type: none"> • Select “dav”, as video playback. • Select “jpg” as picture playback.
Data Source	Default is SD card.

Step 1. Click on data in blue, time axis displays record file progress bar in color. While, green represents normal record, yellow represents motion detect record, red represents alarm record, and blue represents manual record.

Step 2. Click on certain time on progress bar, playback starts from this time. See Figure 3-4.



Figure 3-4

Step 3. Click on file list , select date file will be displayed in list.

Step 4. Double click on file in list, playback this file and display file size, start time and end time.

See Figure 3-5.

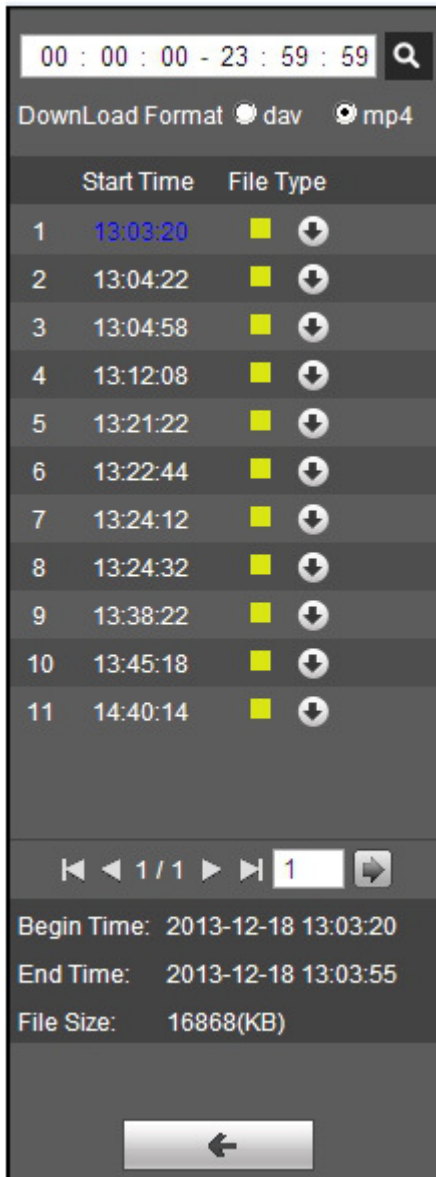

Figure 3-5

Parameter	Function
Search	It means records within searched start time and end time on the date.
Record Download Format	There are two formats: dav, mp4.



Parameter	Function
Download	<ul style="list-style-type: none"> Record type is “dav”, click on download button to download file to local. Record type is “mp4”, click on download button and download file to path in Ch 5.1.2.5. Note: System does not support download and playback of MP4 file.
Back	Click on back button to go to calendar interface.

3.1.3 Playback Cut



Note:

Playback cut function will automatically pause the playing record function. Playback cut and playback cannot be at the same time.

Step 1. Click on start time to cut on time axis. This time must be within progress bar range.

Step 2. Move mouse to cut icon . User will be asked to select start time. Click on cut icon  as finish cutting.

Step 3. Click on playback cut end time on time axis. This time must be within progress bar range.

Step 4. Move mouse to cut icon , user will be asked to select end time. Click on cut icon  as finish cutting.

Step 5. Click on Save button to save file cut to path in Ch 5.1.2.5. See Figure 3-6.

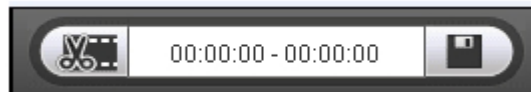

Figure 3-6

3.1.4 Record Type

Check record file type, only selected file will be displayed in progress bar and file list. See Figure 3-7.



Figure 3-7

3.1.5 Progress Bar

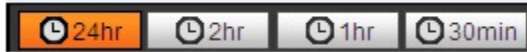

Figure 3-8

Parameter	Function
24 hours	Click on it, means video in past 24 hours.
2 hours	Click on it, means video in past 2 hours.
1 hour	Click on it, means video in past 1 hour.
30 min	Click on it, means video in past 30 min.

3.1.6 Assistant Function

Video playback assistant function is shown in Figure 3-9.



Figure 3-9

Parameter	Function
Zoom in	<ul style="list-style-type: none"> Click on it, video in playback status if is in original size, user can zoom in any area, If it is not in its original size, click on mouse to restore its original size. Click on this button, user may scroll to zoom in.
Snapshot	Click on this button, user may snapshot video under playback status. Snapshot will be saved to path in Ch 5.1.2.5.

3.2 Picture Playback

Web client picture playback interface has the following three functions:

Parameter	Function
1	Play function bar
2	Playback file bar
3	Snapshot type bar

See Figure 3-10.

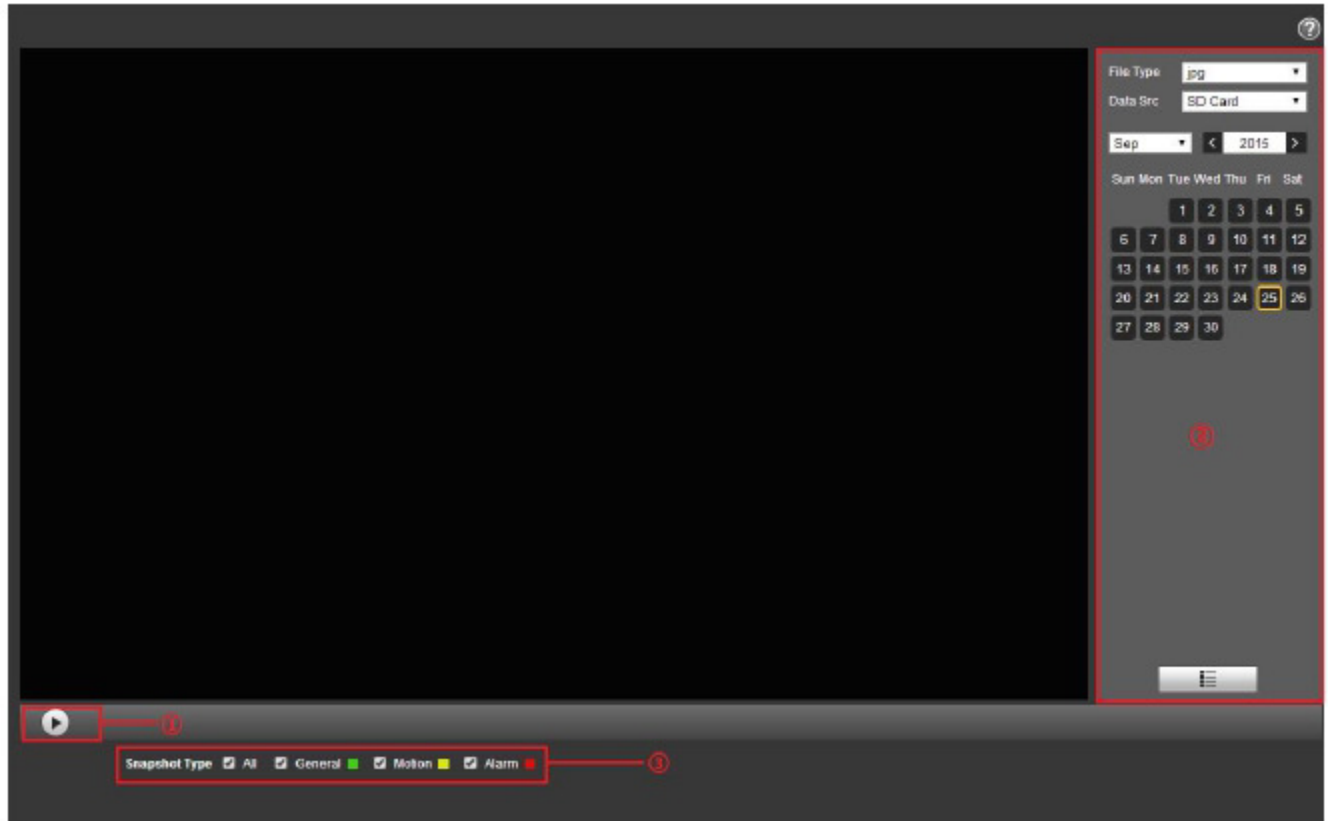



Figure 3-10

3.2.1 Play



Figure 3-11

Default icon is  and it means pause or not played picture. Click on play button to switch to

normal play status. Icon become 

- Click on it to pause.

3.2.2 Playback File

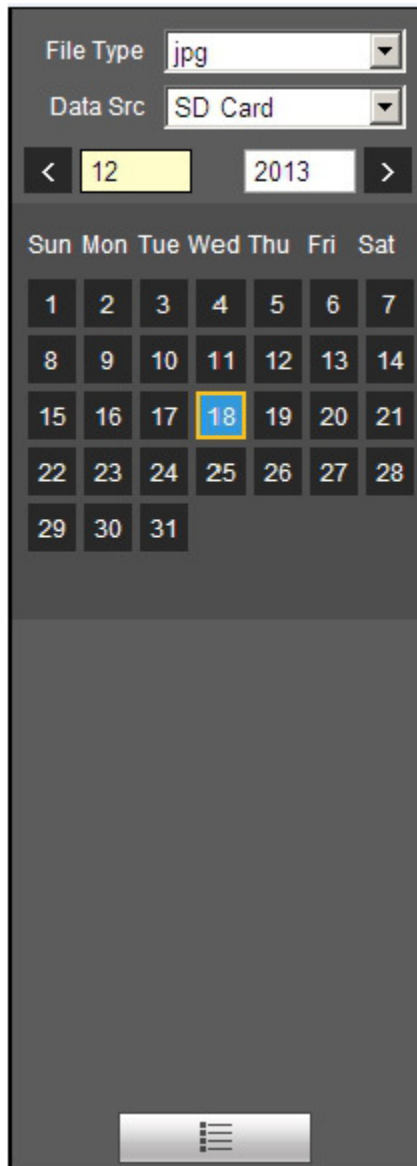

Figure 3-12

Step 1. Click on file list , select snapshot file of the date.

Step 2. Double click on file in list, to play this snapshot.

Parameter	Function
Search	It means all snapshot files within the start time and end time of selected date.

Parameter	Function
Download	Click on download button to download snapshot file to local.
Back	Click on back button to return to calendar interface and re-select time.

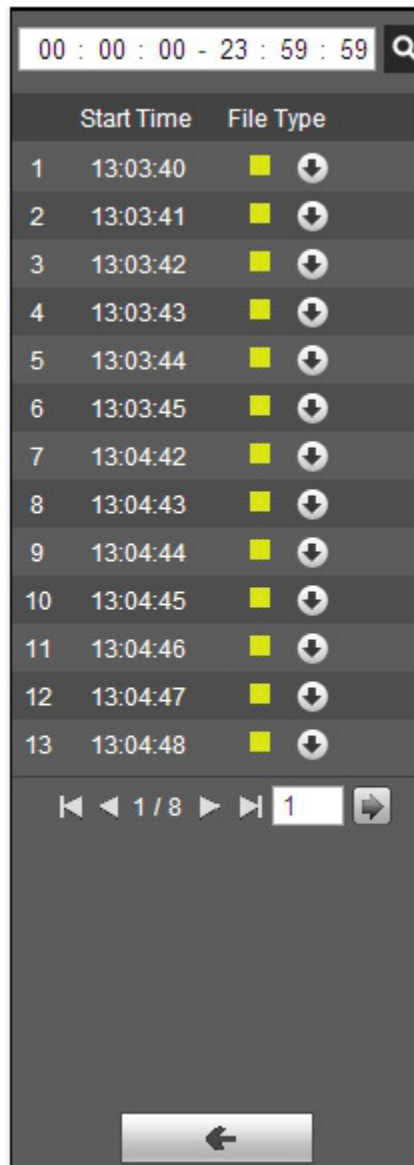

Figure 3-13

3.2.3 Snapshot Type

Check snapshot file type, in file list only display file of selected type. See Figure 3-14.

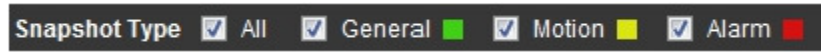

Figure 3-14

4 Report

Attention:

Currently only some models support report function.

The WEB client supports temperature data query of the spot, line and area set by users. Please refer to "5.4.1 Rule Setup" of the settings for spot, line and area.

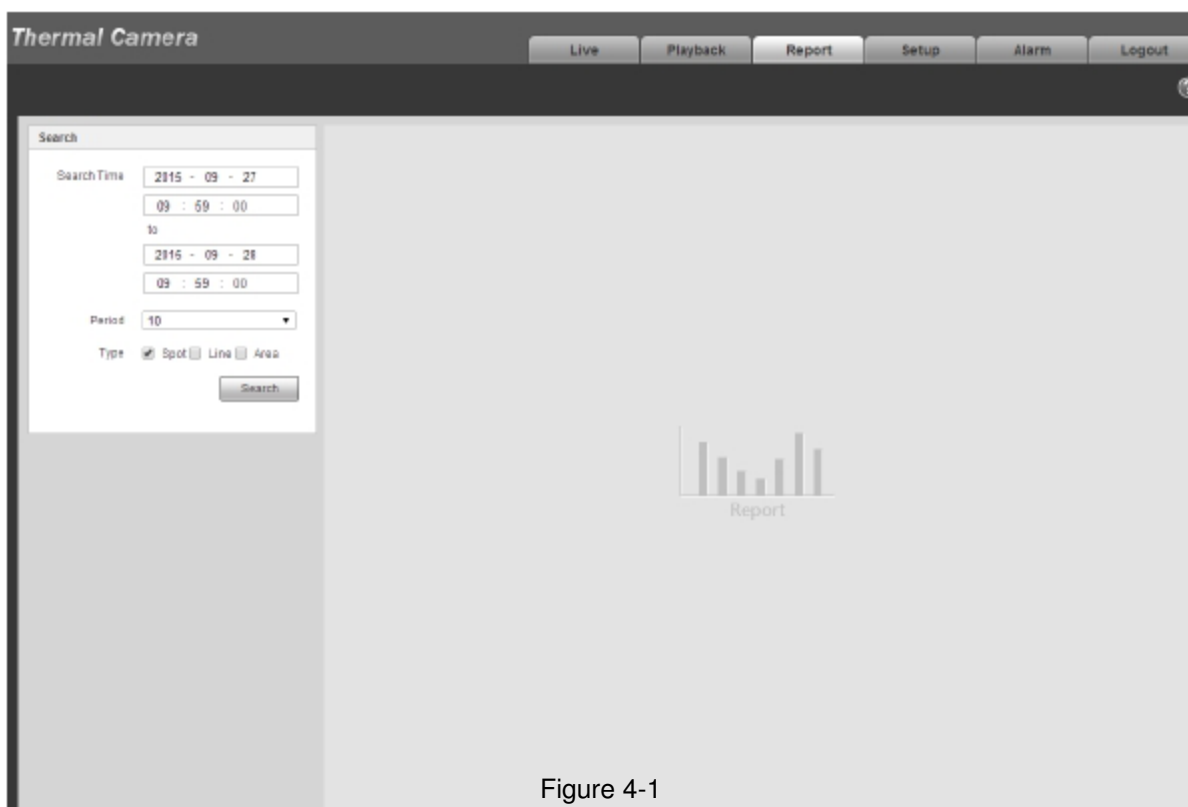

Figure 4-1

Set query condition, click "Search" to check the temperature data within the time period, see Figure 4-2.

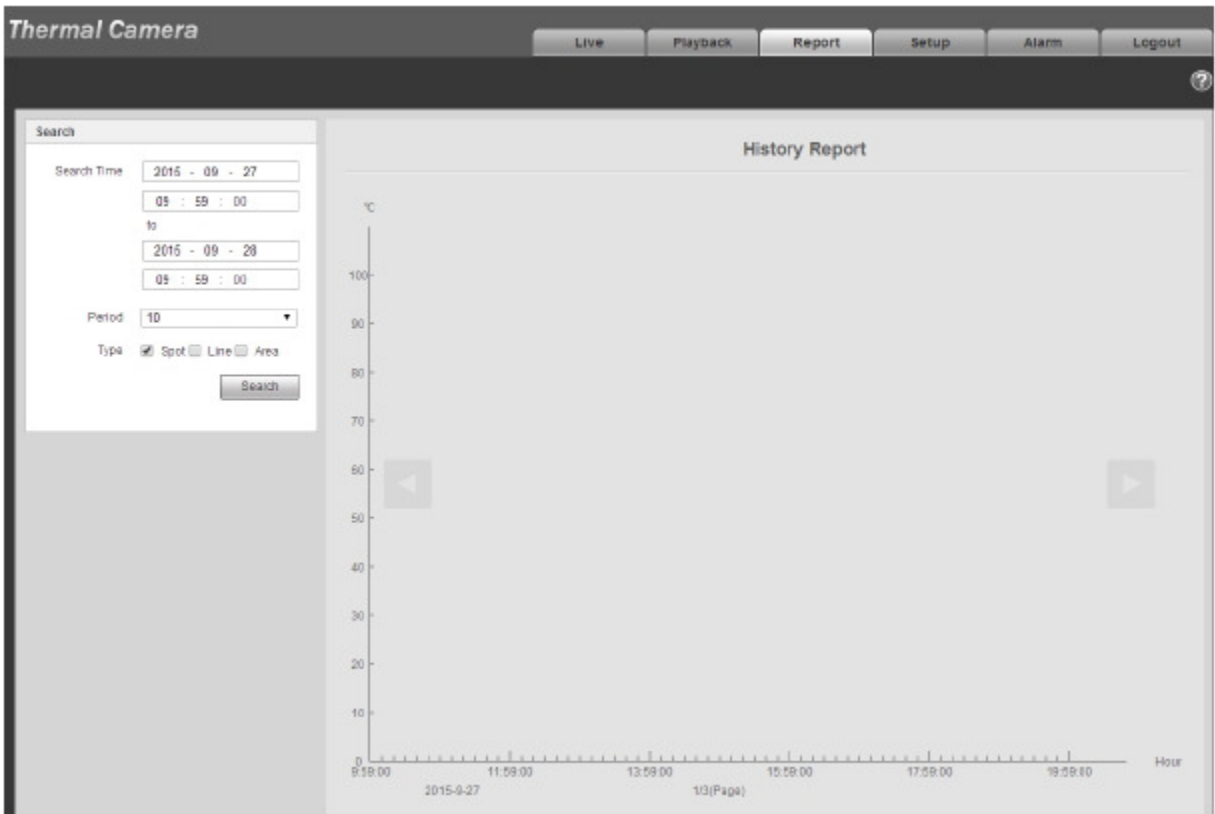

Figure 4-2

5 Setup

Web client setup support camera, network, event, storage, system and system info view.

5.1 Camera

5.1.1 Conditions

Here user may view device property information. Slight differences may be found due to different network camera series. The setups become valid immediately after user set. See Figure 5-1.

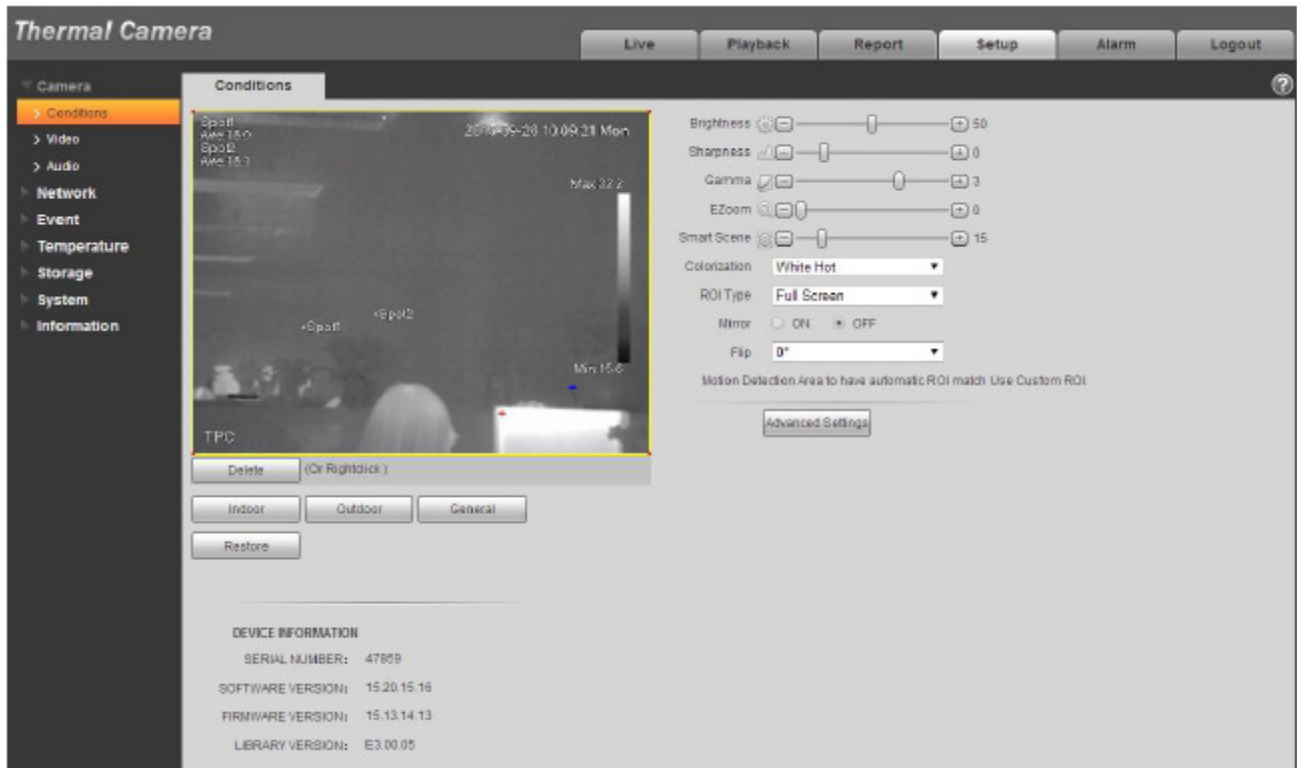

Figure 5-1

Able to set indoor scene, outdoor scene, general scene, user may set and check the config and effect in the corresponding scene after selecting needed scene, please refer to the following sheet for the exact parameters.

Parameter	Function
Brightness	<p>It is to adjust monitor window brightness. User may adjust this value if the video is too dark or too bright. The larger the number, the bright the video is. When user input the value here, the bright section and the dark section of the video will be adjusted accordingly. Please note the video may become hazy if the value is too high.</p> <p>The value ranges from 0 to 100. The recommended value ranges from 40 to 60. The default value is 50.</p>
Sharpness	<p>The value here is to adjust the edge of the video. The larger the value is, the clear the edge is and vice versa. Please note there is noise if the value here is too high.</p> <p>The value ranges from 0 to 100. The recommended value ranges from 5 to 50.</p> <p>The default value is 10.</p>
Gamma	<p>This threshold value mainly changes image contrast according to the relative temperature of the scene.</p> <ul style="list-style-type: none"> ● When the threshold value is > 0, it can increase the contrast of the part with higher temperature in the scene, and weaken the contrast of the part with lower temperature (such as sky and ocean). ● When threshold value is < 0, it can weaken the contrast of the part with higher temperature, and reserve more gray level gradients to increase the part with lower temperature in the scene. <p>The value ranges from -8 to 8. The default value is 3.</p>
EZoom	<p>It can zoom in part of the area in the scene to get clear view.</p>
Smart Scene	<p>The temperature measurement information of the image can be well saved through smart scene function (for example, the gray scale gradient difference between two objects can represent the temperature difference between them). The image contrast will be weakened to some extent.</p> <p>The value ranges from 0~100, default is 15.</p>

Colorization	<p>Able to add color to the IR image, there are 4 colors to select:</p> <p>White Hot: In grayscale image, the place is brighter with higher temperature.</p> <p>Black Hot : In grayscale image, the place is brighter with lower temperature.</p> <p>Ironbow2: Color image with high brightness and contrast.</p> <p>IceFire: In color image, the object with high temperature shows IR, the object with low temperature shows blue. Generally it is used as warning mode.</p> <p>The default is white.</p>
ROI Type	<p>Able to select such modes as: central point 25%, central point 50%, central point 75%, self-define, full screen, bottom, middle and top.</p>
Mirror	<p>Enable it then it will change the left, right direction of video monitoring image. It is disable by default.</p>
Flip	<p>Use this function to change the direction of video monitoring Image. User may select 0°, 90°, 180° and 270°. It is 0° by Default.</p> <p>Note: It needs to set the video resolution as 1080P or lower when using flip mode function.</p>
AGC	<p>It is to set the image AGC; it ranges from 0 to 255.</p>
AGC Max Gain	<p>It is to set the image max AGC gain, it ranges from 0 to 255.</p> <p>The higher the value is, the bigger the image contrast becomes, but with bigger noise.</p>
AGC Plateau	<p>It is to set the image plateau AGC; it ranges from 0 to 255.</p>

Gain Mode	<p>There are three modes to select: low temperature, high temperature and auto, it is low temperature by default. Under auto mode, it can set the threshold of switching low temperature to high temperature, low temperature area percentage, threshold of switching high temperature to low temperature, high temperature area percentage.</p> <ul style="list-style-type: none"> ● Low temperature mode, when the temperature exceeds “threshold of switching low temperature to high temperature” and the pixel point which exceeds threshold is bigger than “low temperature area percentage’, then it will auto switch to high temperature mode. ● High temperature mode, when the temperature is lower than “threshold of high temperature switching to low temperature”, and the pixel point which is lower than threshold is bigger than “high temperature area percentage”, then it will auto switch to low temperature mode. ● Setting rules: the temperature threshold of low temperature switching to high temperature needs to be higher than that of high temperature switching to low temperature, the sum of two area percentage need to be bigger than 100.
Device Information	Display device serial number, software version and firmware version.

Click “Restore” to make the “Camera Condition” back to original state.

5.1.2 Video

5.1.2.1 Video bit stream

The video bit stream interface is shown as below. See Figure 5-2.

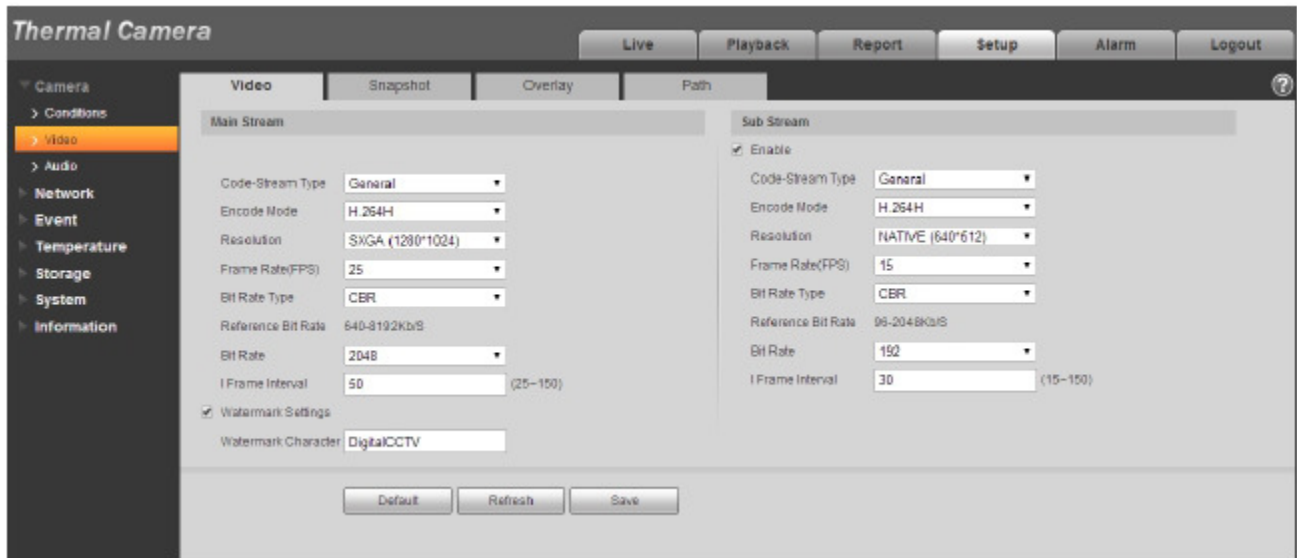

Figure 5-2

Note:

Different stream may be corresponding to different default value, please refer to the actual interface for details.

Please refer to the following sheet for detailed information.

Parameter	Function
Code-Stream Type	ACF means using different fps to record. There are two options: VBR and CBR. Please note, user may set video quality in VBR mode.
Encode mode	There are four options: H.264 (main profile standard, H.264H (high profile standard), and MJPEG encode. <ul style="list-style-type: none"> ● The H.264, H.264H both are H264 bit stream. H.264 is the Main Profile encode and user need to enable the sub stream function in user camera and set the resolution as CIF. Then user may monitor via the Blackberry cell phone. ● MJPEG: In this encode mode, the video needs large bit stream to guarantee the video definition. User may use the max bit stream value in the recommended bit to get the better video output effect.

Parameter	Function
Resolution	There are multiple resolutions. User may select from the dropdown list. For each resolution, the recommended bit stream value is different. Note: When video is under rotating status, user may not set resolution higher than 1080P (excluding 1080P).
Frame Rate	PAL: 1~25f/s, NTSC: 1~30f/s.. The frame rate may vary due to different resolutions.
Bit Rate Type	There are two options: VBR and CBR. Please note, user may set video quality in VBR mode. Under MJPEG mode, only CBR is available.
Recommended Bit	Recommended bit rate value according to the resolution and frame rate user have set.
Bit Rate	<ul style="list-style-type: none"> ● In CBR, the bit rate here is the max value. In dynamic video, system needs to low frame rate or video quality to guarantee the value. ● The value is null in VBR mode. ● Please refer to recommend bit rate for the detailed information.
I Frame	Here user may set the P frame amount between two I frames. The value ranges from 1 to 150. Default value is 50. Recommended value is frame rate *2.
Watermark Settings	By calibrating watermark, to see if video is modified. Select Watermark function. Default watermark is Digital CCTV. Watermark character can only be number, letter, _, - within 128 characters.

5.1.2.2 Snapshot

The snapshot interface is shown as in Figure 5-3.

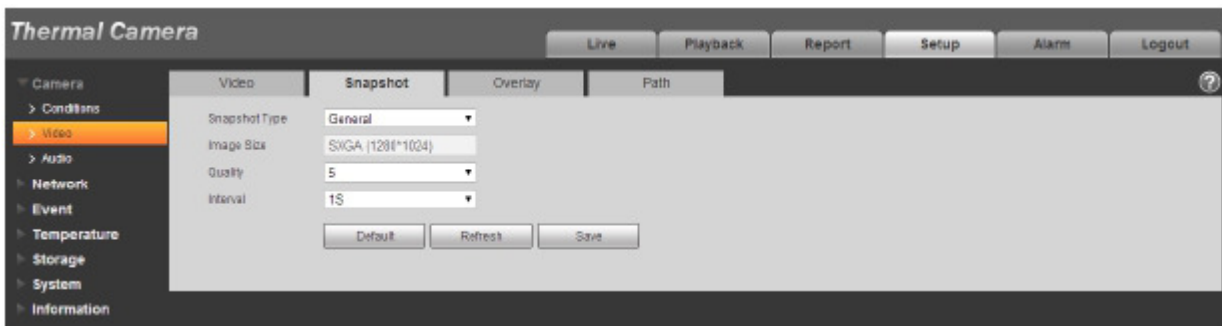

Figure 5-3

Please refer to the following sheet for detailed information.

Parameter	Function
Snapshot type	There are two modes: General (schedule) and Event (activation). <ul style="list-style-type: none"> ● General: to snapshot in the area set by the schedule. ● Event: to snapshot after triggering motion detect and local alarm,
Image size	It is the same with the resolution of snapshot (main stream or sub stream).
Quality	It is to set the image quality. There are six levels.
Interval	It is to set snapshot frequency. The value ranges from 1s to 7s.

5.1.2.3 Video Overlay

The video overlay interface is shown as in Figure 5-4.

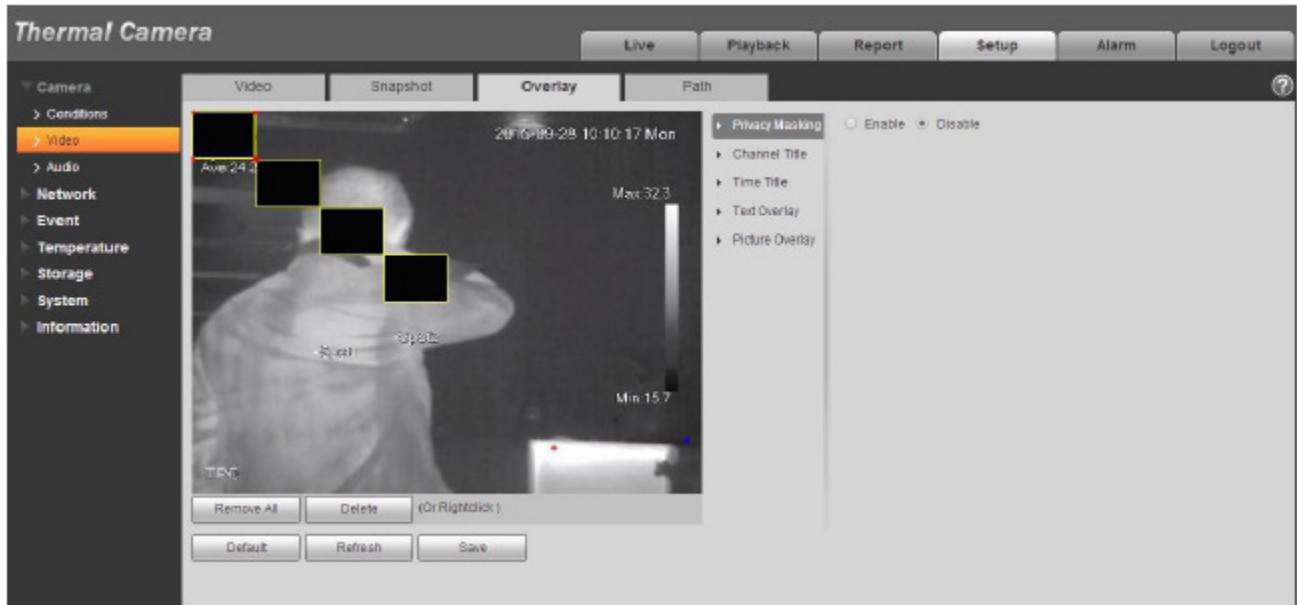

Figure 5-4

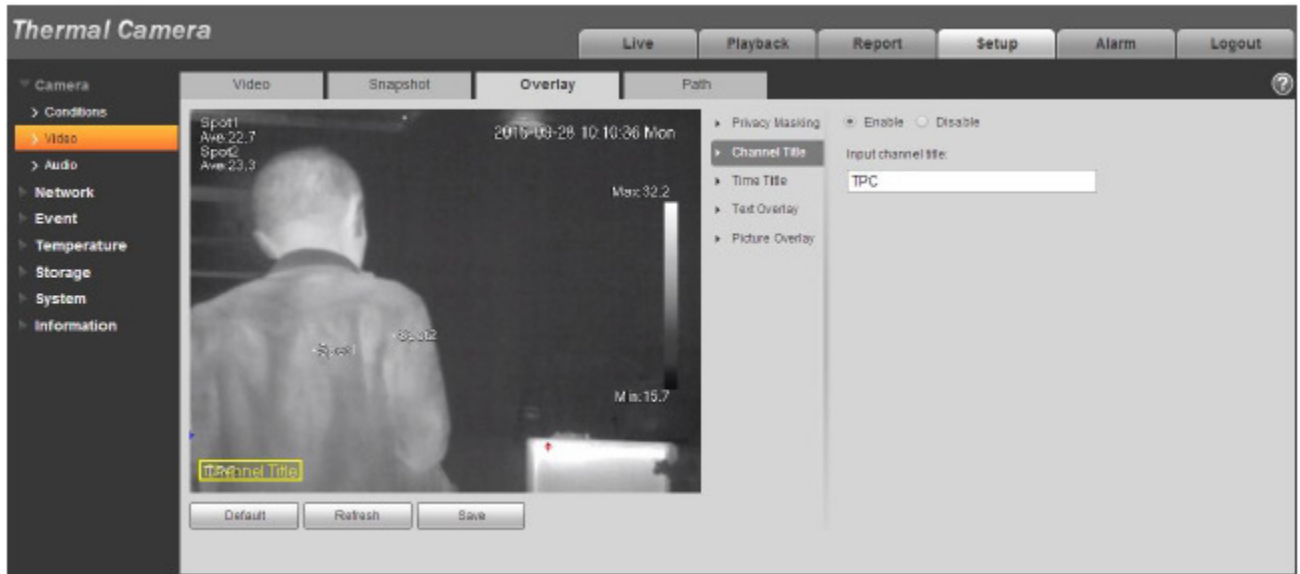

Figure 5-5



Figure 5-6



Figure 5-7

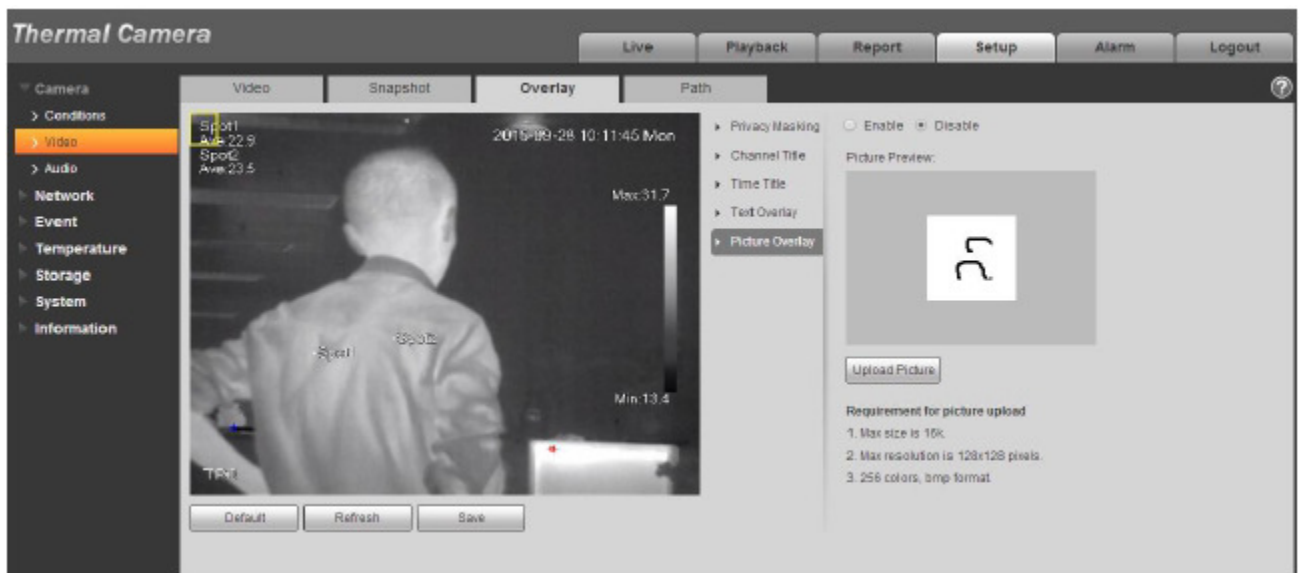

Figure 5-8

Please refer to the following sheet for detailed information.

Parameter	Function
Privacy mask	<ul style="list-style-type: none"> ● Here user may privacy mask the specified video in the monitor video. ● System max supports 4 privacy mask zones.

Time Title	<ul style="list-style-type: none"> ● User may enable this function so that system overlays time information in video window. ● User may use the mouse to drag the time tile position.
Channel Title	<ul style="list-style-type: none"> ● User may enable this function so that system overlays channel information in video window. ● User may use the mouse to drag the channel tile position.
Location	<ul style="list-style-type: none"> ● User may enable this function to overlay location information in video window. ● User may click on setup button to set location information. User may use the mouse to drag location box to adjust its position. Alignment include align left and align right.
Overlay	<ul style="list-style-type: none"> ● User may enable this function to display overlay picture. Click on disable to turn it off. ● Click on Upload Picture to overlay local picture into monitoring window. User may drag the yellow box to move it. <p>Note: User may not enable location and overlay at the same time.</p>
Refresh	<ul style="list-style-type: none"> ● Set privacy mask, channel title, time title, location, overlay and save the change. User may click on Refresh to see effect.

5.1.2.4 Path

The storage path interface is shown as in Figure 5-9.

Here user may set snap image saved path and the record storage path.

- The default monitor image path is C:\Documents and Settings\Administrator\WebDownload\Snapshot.
- The default monitor record path is C:\Documents and Settings\Administrator\WebDownload\LiveRecord.
- The default playback snapshot path is C:\Documents and Settings\Administrator\WebDownload\PlaybackSnapshot.
- The default playback download path is C:\Documents and Settings\Administrator\WebDownload\PlaybackRecord.
- The default playback cut path is: C:\Documents and Settings\Administrator\WebDownload\VideoClips.
- The heat map path is: C:\Documents and Settings\Administrator\WebDownload\heatmap

Note:

Administrator is locally logged in PC account.

Please click the Save button to save current setup.

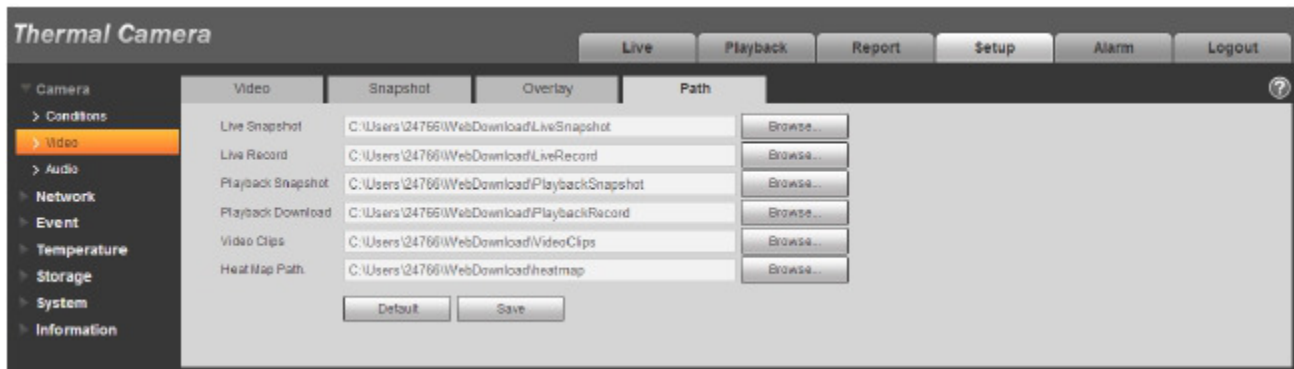

Figure 5-9

5.1.3 Audio

Please note some series devices do not support audio function.

5.1.3.1 Audio

The audio interface is shown as below. See Figure 5-10.

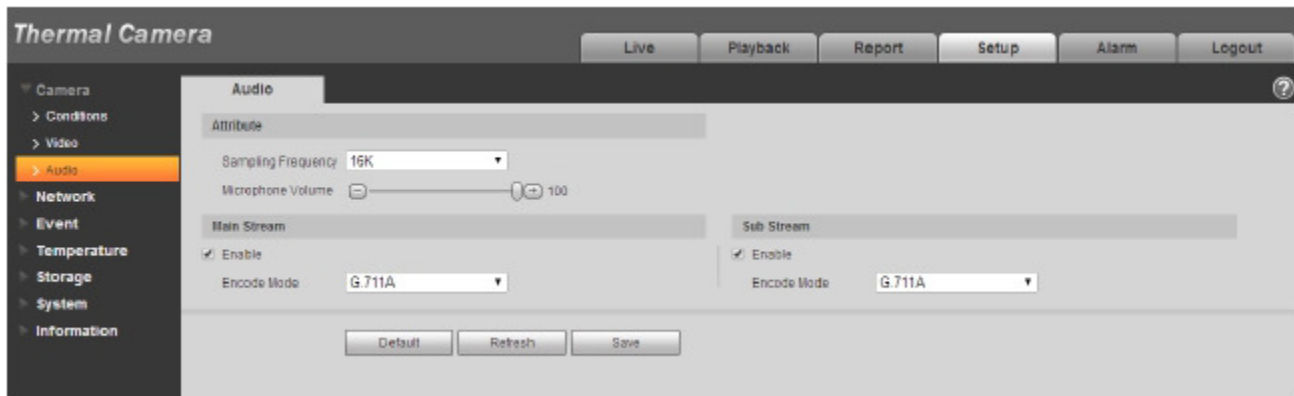

Figure 5-10

Please refer to the following sheet for detailed information.

Parameter	Function
Sampling Frequency	It includes two types of frequency: 8k and 16k.
Microphone Volume	It is to set the microphone volume.
Audio enable	<ul style="list-style-type: none"> ● Check “Enable”, the stream is A/V composite stream, otherwise it contains video only. ● Audio is available only when video is enabled.
Encode mode	The encode mode includes three modes: G.711A, G.711Mu and AAC. The default is G.711A.

5.2 Network

5.2.1 TCP/IP

The TCP/IP interface is shown as in Figure 5-11. It supports IPv4 and IPv6. IPv4 supports static IP and DHCP. IPv6 supports static IP only. When users manually modify IP address, WEB will automatically jump to the new IP address.

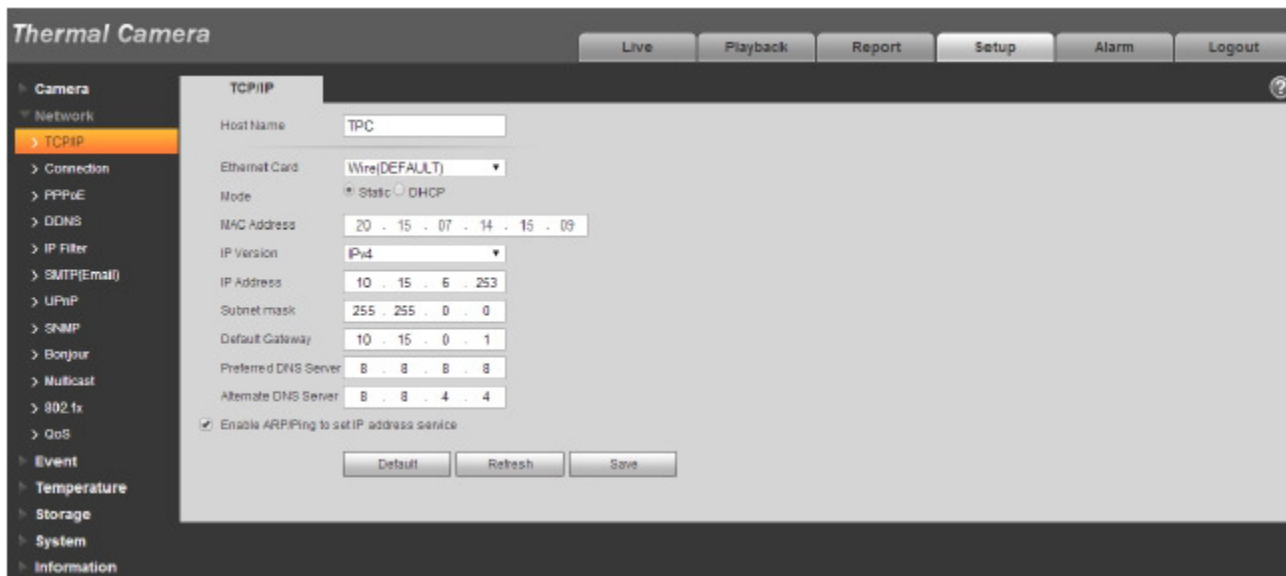

Figure 5-11

Please refer to the following sheet for detailed information.

Parameter	Function
Host Name	It is to set current host device name. It max supports 15 characters.
Ethernet Card	Please select the Ethernet port. Default is wired. Please note user may modify the default Ethernet card if there is more than one card. . Please note the device needs to reboot to activate the new setup once user modify the default setup.
Mode	There are two modes: static mode and the DHCP mode. Select DHCP mode, it auto searches IP, and user may not set IP/subnet mask/gateway. Select static mode, user must manually set IP/subnet mask/gateway.
Mac Address	It is to display hose Mac address.

IP Version	It is to select IP version. IPV4 or IPV6. User may access the IP address of these two version.
IP Address	Please use the keyboard to input the corresponding number to modify the IP address and then set the corresponding subnet mask and the default gateway.
Preferred DNS	DNS IP address.
Alternate DNS	Alternate DNS IP address.
Enable ARP/Ping set device IP address service.	<p>User may use ARP/Ping command to modify or set the device IP address if user know the device MAC address.</p> <p>Before the operation, please make sure the network camera and the PC in the same LAN. This function is on by default.</p> <p>User may refer to the steps listed below.</p> <p>Step 1: Get an IP address. Set the network camera and the PC in the same LAN.</p> <p>Step 2: Get the physical address from the label of the network camera.</p> <p>Step 3: Go to the Run interface and then input the following commands.</p> <pre>arp -s <IP Address> <MAC> ping -l 480 -t <IP Address></pre> <p>Such as : arp -s 192.168.0.125 11-40-8c-18-10-11 ping -l 480 -t 192.168.0.125</p> <p>Step 4: Reboot the device.</p> <p>Step 5: User may see the setup is OK if user may see there are output information such as “Reply from 192.168.0.125 ...” from the command output lines. Now user may close the command line.</p> <p>Step 6: Open the browse and then input http://<IP address>. Click the Enter button, user may access now.</p>

5.2.2 Connection

5.2.2.1 Connection

The connection interface is shown as in Figure 5-12.

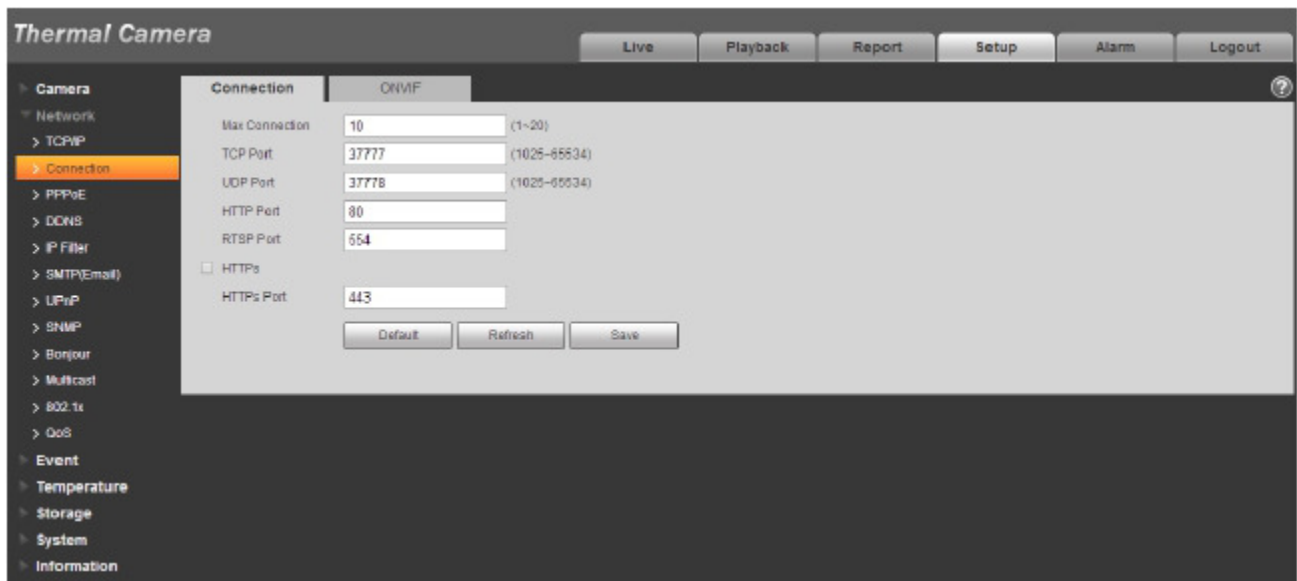

Figure 5-12

Please refer to the following sheet for detailed information.

Parameter	Function
Max connection	It is the max Web connection for the same device. The value ranges from 1 to 20. Default connection amount is 10.
TCP port	Port range is 1025~65534. The default value is 37777. User may input the actual port number if necessary.
UDP port	Port range is 1025~65534. The default value is 37778. User may input the actual port number if necessary.
HTTP port	Port range is 1025~65524. The default value is 80. User may input the actual port number if necessary.

RTSP port	<ul style="list-style-type: none"> ● The default value is 554. Please leave blank if use default. User uses QuickTime or VLC can play the following formats. BlackBerry can play too. ● Real-time monitoring URL format, please require real-time RTSP media server, require channel no., bit stream type in URL. User may need username and password. ● User uses BlackBerry need to set encode mode to H.264B, resolution to CIF and turn off audio. <p>URL format is: rtsp://username:password@ip:port/cam/realmonitor?channel=1&subtype=0 username/password/IP and port.</p> <p>The IP is device IP and the port default value is 554. User may leave it in blank if it is the default value.</p> <p>Follow standard RTP protocol and when encode mode is MJPEG, the max resolution only supports 2040*2040.</p>
HTTPs Enable	Check HTTPs enable, login as https://ip:port. Protect data. Default port is https://ip . It is disabled by default.
HTTPs Port	HTTPs communication port, range is 1025~65534, default is 443.

Note:

- 0~1024, 37780~37880, 1900, 3800, 5000, 5050, 9999, 37776, 39999, 42323 are all special ports. User cannot modify them.
- Avoid using default port value of other ports.

5.2.2.1 ONVIF

ONVIF (Open Network Video Interface Forum) , this standard describes network video mode, interface, data type and data interaction mode. ONVIF Standard's aim is to achieve a network video frame agreement and makes the network video products (including video front-end, video equipment, etc.) from different manufacturers completely compatible.

ONVIF function default is closed.

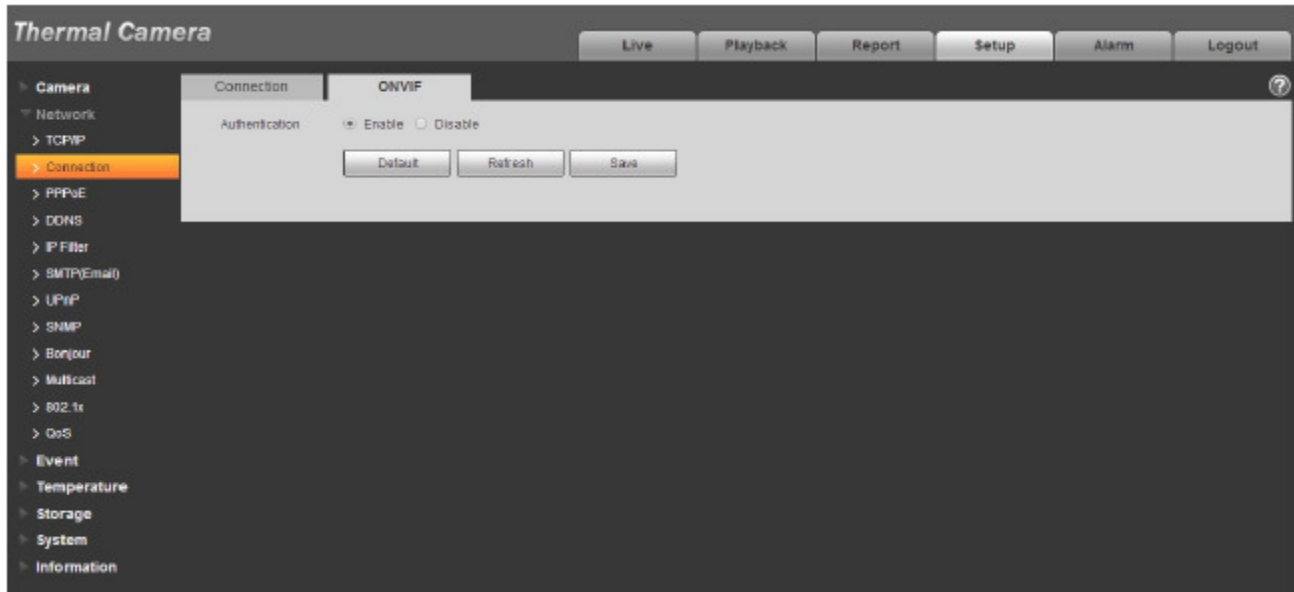

Figure 5-13

5.2.3 PPPoE

The PPPoE interface is shown as in Figure 5-14.

Input the PPPoE user name and password user get from the IPS (internet service provider) and enable PPPoE function. Please save current setup and then reboot the device to get the setup activated.

Device connects to the internet via PPPoE after reboot. User may get the IP address in the WAN from the IP address column. When PPPoE is on, please disable UPnP to avoid influence on dial-up.

When user Check PPPoE enable, please disable UPnP.

Please note, user need to go to the IP address item to via the device current device information.

User may access the client-end via this address.

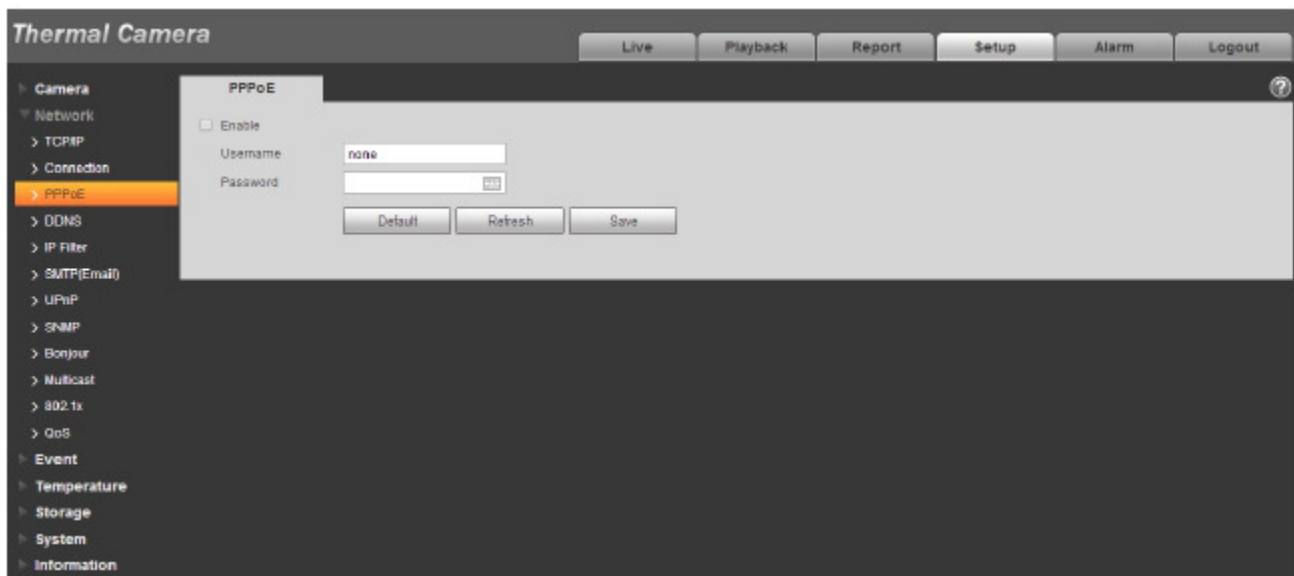

Figure 5-14

5.2.4 DDNS

The DDNS interface is shown as in Figure 5-15.

The DDNS is to set to connect the various servers so that user may access the system via the server. Please go to the corresponding service website to apply a domain name and then access the system via the domain. It works even user IP address has changed. When the device connects to WLAN, user should disable UPnP.

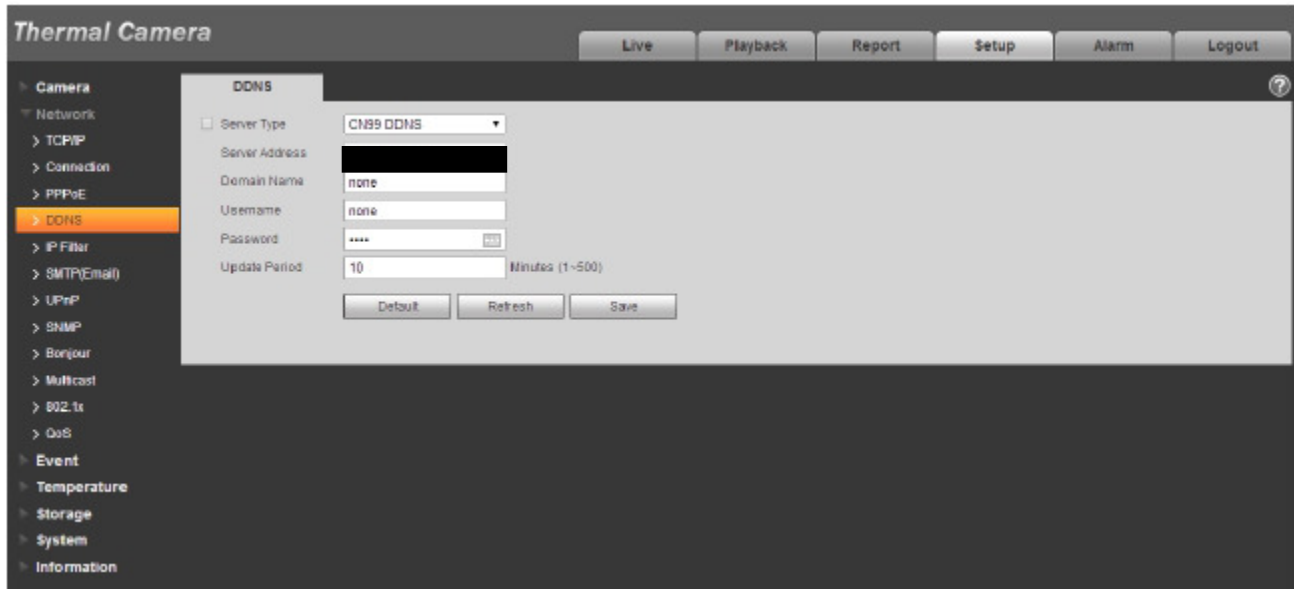

Figure 5-15

Parameter	Function
Server Type	User may select CN99 DDNS protocol
Server Address	Under CN99 DDNS the default server address is “www.3322.org”
Domain Name	Self-defined domain name
Username	The user name user input to log in the server.
Password	The password user input to log in the server
Refresh Period	The refresh period of the connection between the device IP and the server, default is 10 minutes.

5.2.5 IP filter

The IP filter interface is shown as in Figure 5-17.

User may enable IP filter function so that some specified IP/MAC user can access the network camera. User may add IP address or IP address section.

If user does not check the box here, it means there is on access limit.

Here user may add IP address and MAC address. User must add these addresses before enabling the trusted sites.

Please note: User must set MAC address in the same network segment.

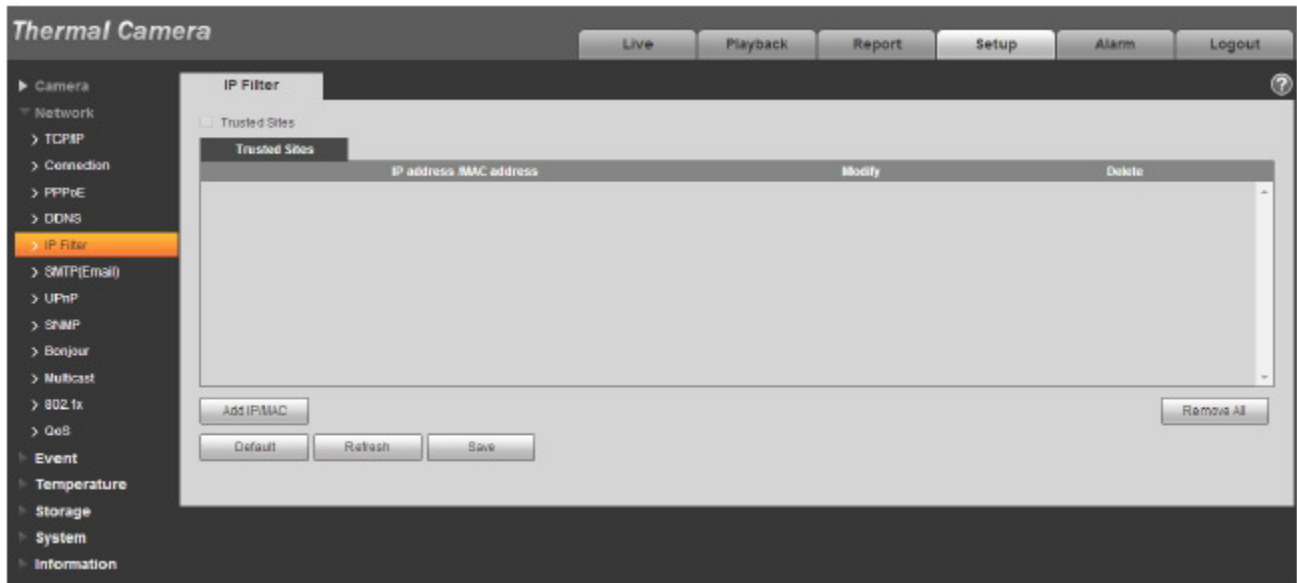

Figure 5-17

5.2.6 SMTP (e-mail)

The SMTP interface is shown as in Figure 5-18.

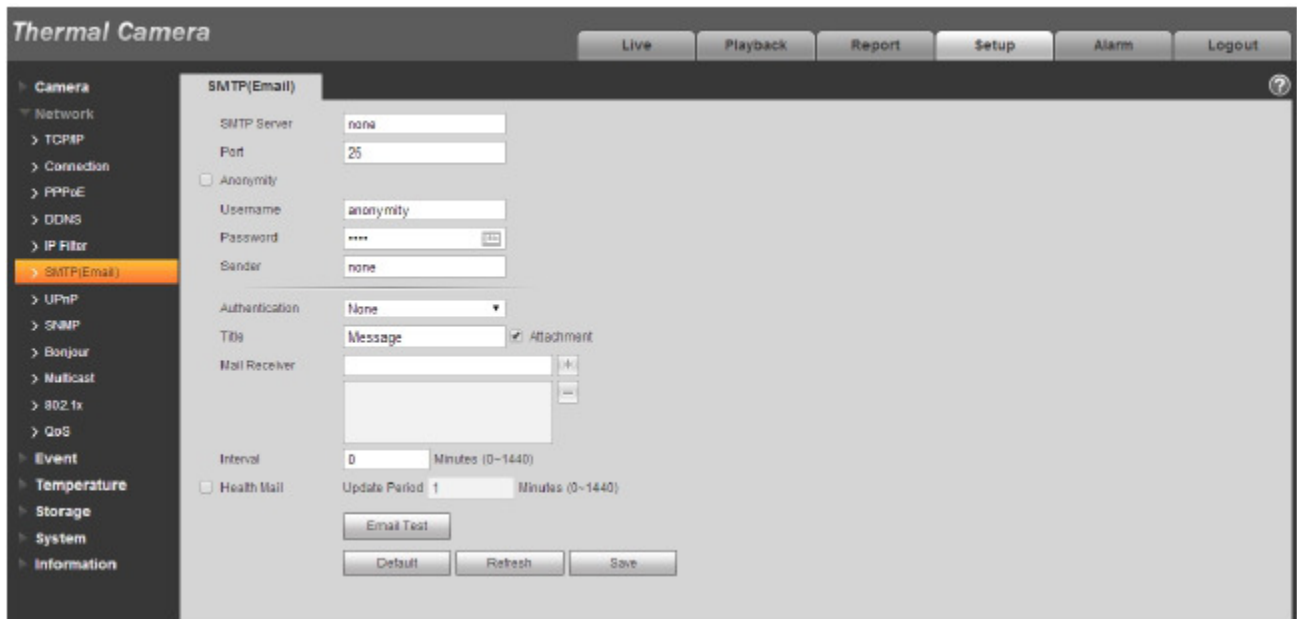

Figure 5-18

Please refer to the following sheet for detailed information.

Parameter	Function
SMTP Server	Input server address and then enable this function.
Port	Default value is 25. User may modify it if necessary.
Anonymity	For the server supports the anonymity function. User may auto login anonymously. User do not need to input the user name, password and the sender information.
User Name	The user name of the sender email account.
Password	The password of sender email account.
Sender	Sender email address.
Authentication (Encryption mode)	User may select SSL, TLS or none.
Title (Subject)	Input email subject here.
Attachment	System can send out the email of the snapshot picture once user check the box here.
Mail receiver	Input receiver email address here. Max three addresses.
Interval	The send interval ranges from 0 to 3600 seconds. 0 means there is no interval. Please note system will not send out the email immediately when the alarm occurs. When the alarm, motion detection or the abnormality event activates the email, system sends out the email according to the interval user specified here. This function is very useful when there are too many emails activated by the abnormality events, which may result in heavy load for the email server.
Health mail enable	Please check the box here to enable this function.
Email test	The system will automatically sent out a email once to test the connection is OK or not .Before the email test, please save the email setup information.

5.2.7 UPnP

It allows user to establish the mapping relationship between the LAN and the public network.

Here user may also add, modify or remove UPnP item. For UPnP on different routers, user must disable UPnP function. See Figure 5-19.

In the Windows OS, From Start->Control Panel->Add or remove programs. Click the “Add/Remove Windows Components” and then select the “Network Services” from the Windows Components Wizard. Click the Details button and then check the “Internet Gateway Device Discovery and Control client” and “UPnP User Interface”. Please click OK to begin installation.

Enable UPnP from the Web. If user UPnP is enabled in the Windows OS, the network camera can auto detect it via the “My Network Places”.

Under manual mode, user may modify external port. Under auto mode, select idle port for auto port mapping without user modification.



Figure 5-19

5.2.8 SNMP

The SNMP interface is shown as in Figure 5-20 and Figure 5-21.

The SNMP allows the communication between the network management work station software and the proxy of the managed device. Please install the software such as MG MibBrowser 8.0c software or establish the SNMP service before user uses this function. User need to reboot the device to activate the new setup.

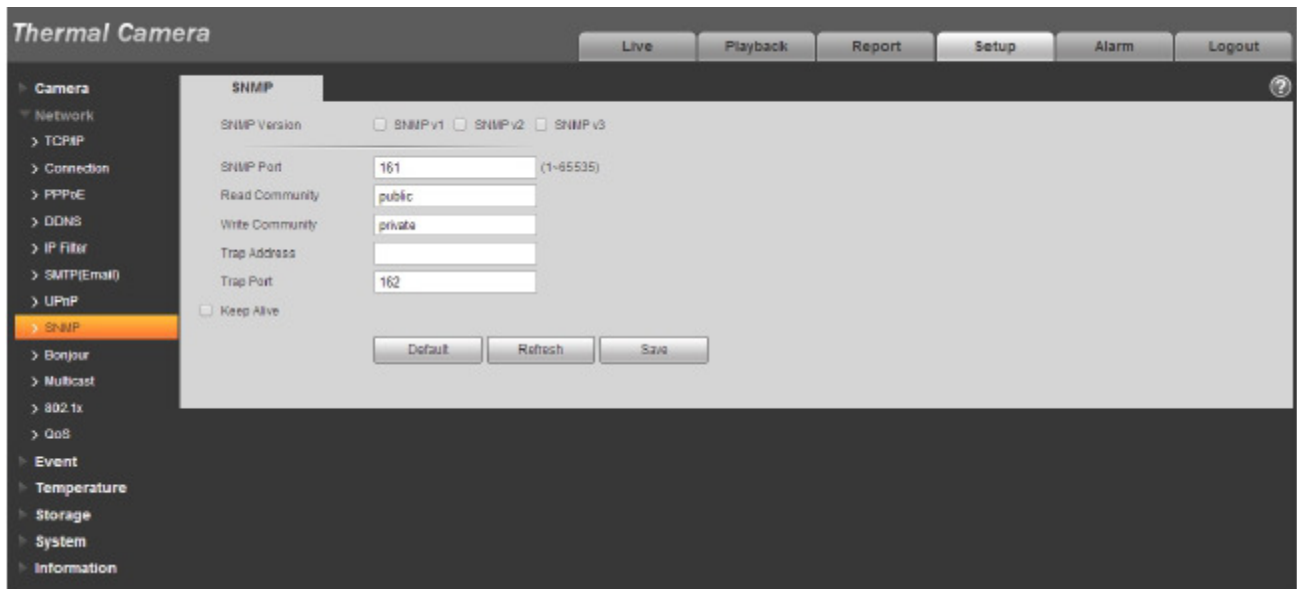

Figure 5-20

Please refer to the following sheet for detailed information.

Parameter	Function
SNMP Version	<ul style="list-style-type: none"> ● Check SNMP v1, device only process v1 info. ● Check SNMP v2, device only process v2 info. ● Check SNMP v3, can set username, password and encryption method. Server calibrate corresponding username, password and encryption method too access device and v1/v2 are unavailable.
SNMP port	The listening port of the proxy program of the device. It is a UDP port not a TCP port. The value ranges from 1 to 65535. The default value is 161
Community	It is a string, as command between management and proxy, , defining a proxy, and a manager's authentication.
Read community	Read-only access to all SNMP targets, default is public. Note: Only number, letter, _, and – supported.
Write community	Read/write access to all SNMP targets, default is private. Note: Only number, letter, _, and – supported.
Trap address	The destination address of the Trap information from the proxy program of the device.
Trap	SNMP trap is a proxy message sent to admin as important event notice or status change.
Trap Address	Address where to send Trap message.

Parameter	Function
Trap Port	Port which send Trap message, default is 162, range 1~65535.

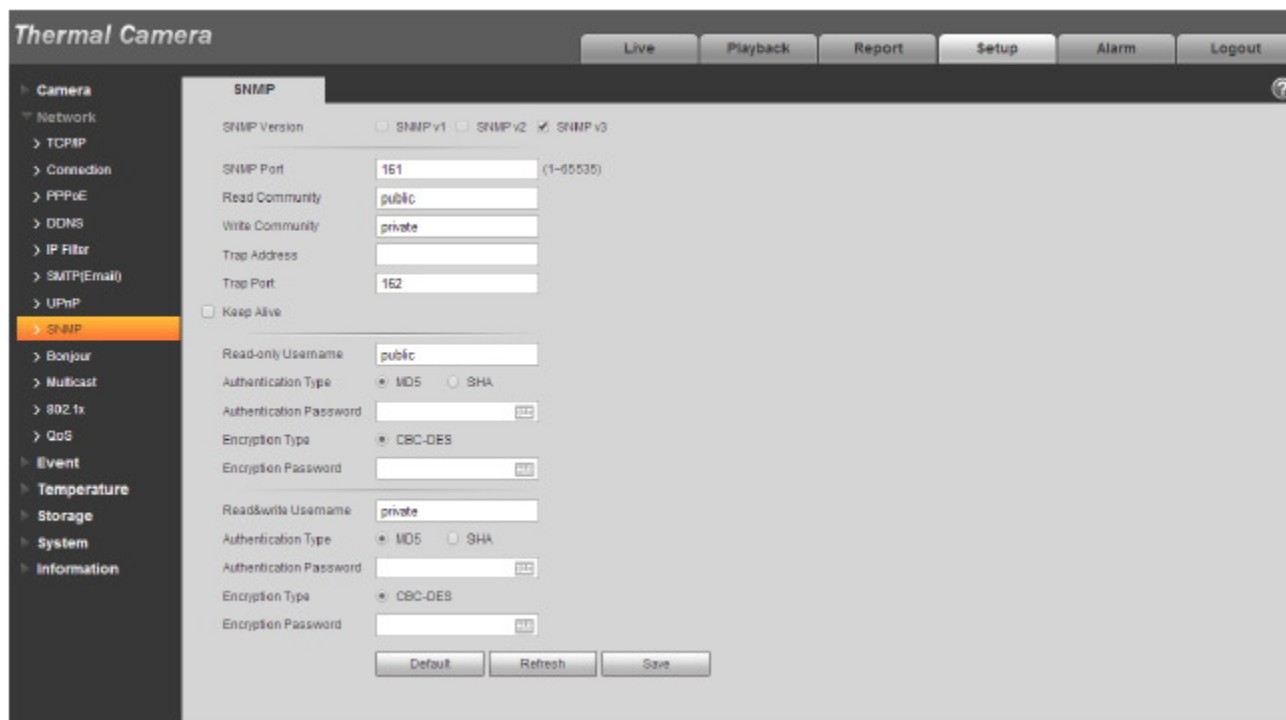

Figure 5-21

Check SNMP v3 version and SNMP port, read community, write community, Trap address, Trap port are same with SNMP v1 and SNMP v2 versions. Only when SNMP version is SNMP v3, users need to configure parameter in chart.

Parameter	Function
SNMP Version	SNMP v3
Read-only Username	Default is public. Note: Name only can be number, letter and underline.
Read/Write Username	Default is private. Note: Name only can be number, letter and underline.
Authentication	User may select MD5 or SHA, default is MD5.
Authentication Password	Password not less than 8 characters.

Parameter	Function
Encryption	Default is CBC-DES.
Encryption Password	Password not less than 8 characters.

5.2.9 Bonjour

The Bonjour interface is shown as below. See Figure 5-22.

Bonjour is based on the multicast DNS service from the Apple. The Bonjour device can automatically broadcast its service information and listen to the service information from other device.

User may use the browse of the Bonjour service in the same LAN to search the network camera device and then access if user do not know the network camera information such as IP address.

User may view the server name when the network camera is detected by the Bonjour. Please note the safari browse support this function. Click the “Display All Bookmarks: and open the Bonjour, system can auto detect the network camera of the Bonjour function in the LAN.

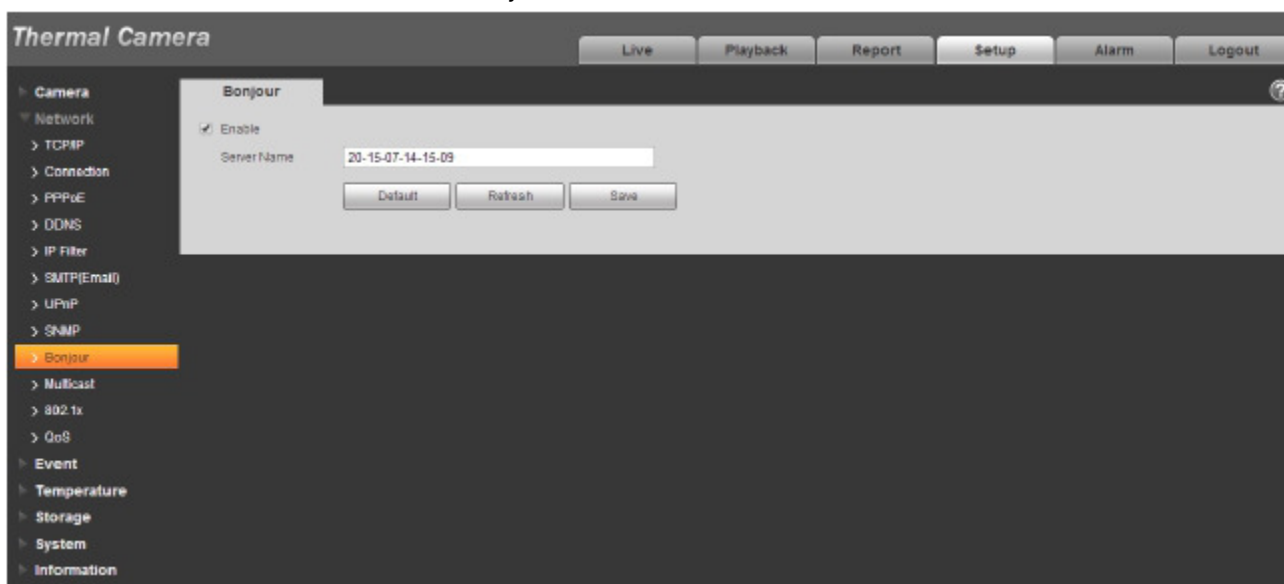

Figure 5-22

5.2.10 Multicast

The multicast interface is shown as in Figure 5-23.

Multicast is a transmission mode of data packet. When there is multiple-host to receive the same data packet, multiple-cast is the best option to reduce the broad width and the CPU load. The source host can just send out one data to transit. This function also depends on the relationship of the group member and group of the outer.

Note:

- Open preview, streaming media protocol, select multicast, and monitor via multicast format.

- Here user may set multicast address and port. User also need to go to Live interface to set the protocol as Multicast.

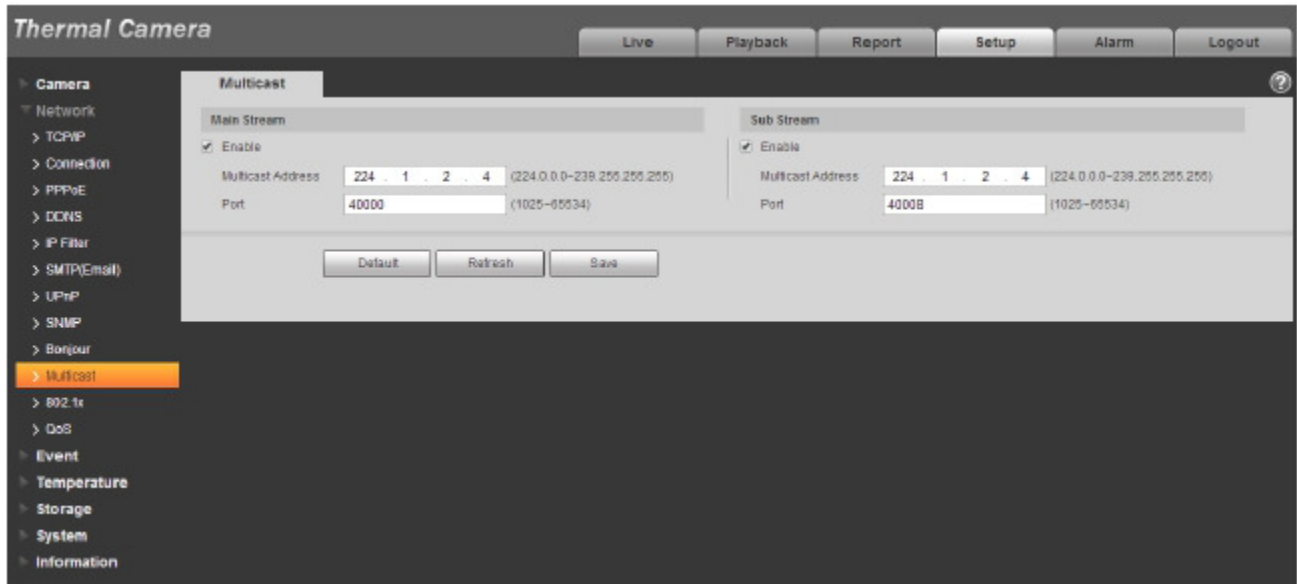

Figure 5-23

Please refer to the following sheet for detailed information.

Parameter	Function
Enable	Select to enable multicast function. Main stream and sub stream cannot be used at the same time.
Multicast address	Main/sub stream multicast default address is 224.1.2.4 and its range is 224.0.0.0~239.255.255.255.
Port	Multicast port. Main stream is 40000, sub stream is 40002 and the range is 1025~65534.

5.2.11 802.1x

802.1x (port based network access control protocol) supports manual selection of authentication method to control if device connected to LAN can join the LAN. It well supports authentication, charging, safety and management requirement of network.

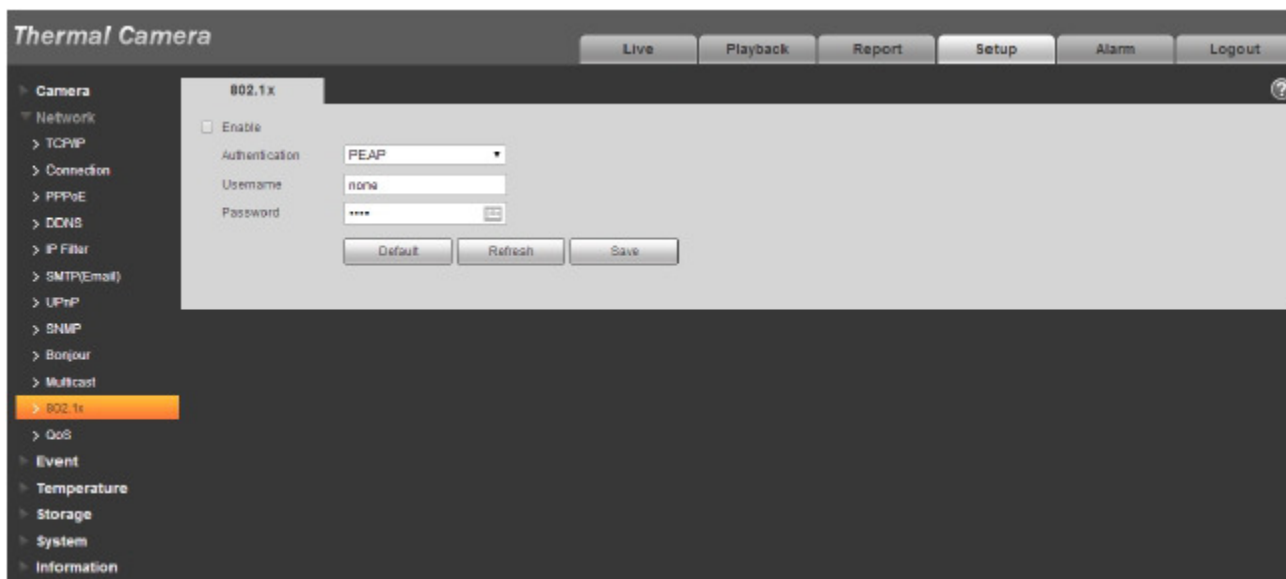

Figure 5-24

Please refer to the following sheet for detailed information.

Parameter	Function
Authentication	PEAP (protected EAP protocol).
Username	It needs the username to login, which is authenticated by the server.
Password	Please input password here.

5.2.12 QoS

The QoS interface is shown as below. See Figure 5-25.

Qos (Quality of Service) is network security mechanism. It is a technology to fix the network delay and jam problem and etc. For the network service, the quality of service includes the transmission bandwidth, delay, the packet loss and etc. We can guarantee the transmission bandwidth, lower the delay, reduce the loss of the data packet and anti-dither to enhance the quality.

We can set the DSCP (Differentiated Services Code Point) of the IP to distinguish the data packet so that the router or the hub can provide different services for various data packets. It can select the different queues according to the priority (64 different priority levels) of the packets and select the bandwidth of the each queue. Level 0 is the lowest, and level 63 is the highest. It can also discard at the different ratio when the broad bandwidth is jammed.

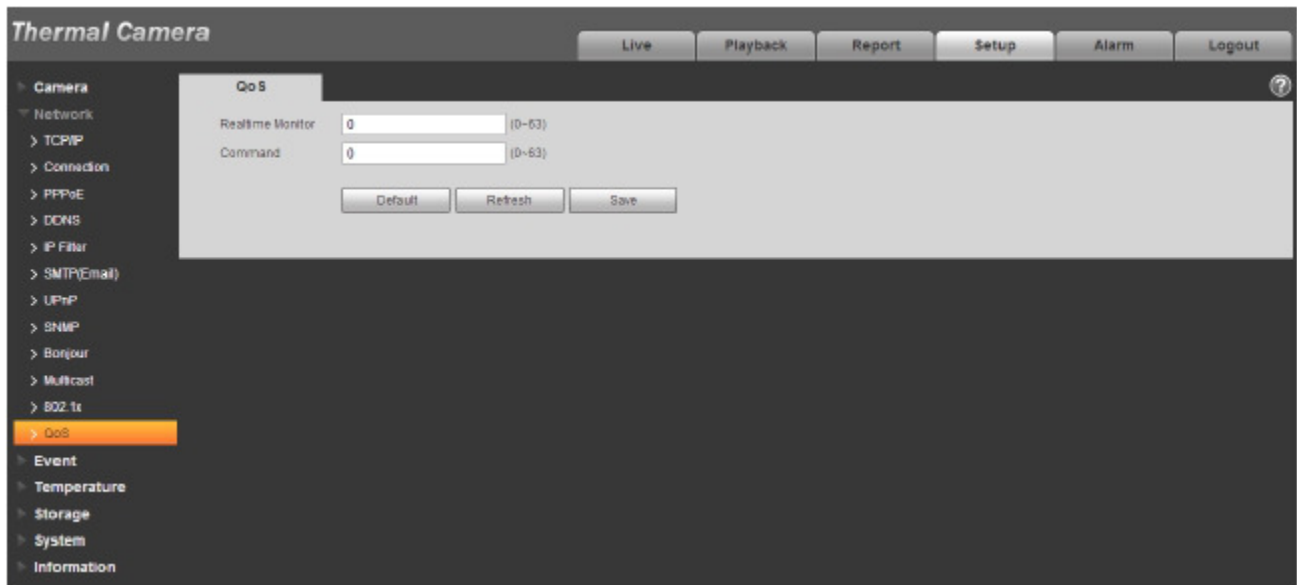

Figure 5-25

Please refer to the following sheet for detailed information.

Parameter	Function
Real-time monitor	The value ranges from 0 to 63. The router or the switcher can provide different service for various data packets.
Command	The value ranges from 0 to 63. The router or the switcher can provide different service for various data packets.
Enable Wireless QoS	Check it to enable QoS.

5.3 Event

5.3.1 Video detect

5.3.1.1 Motion Detect

The motion detect interface is shown as in Figure 5-26 through Figure 5-27.



Figure 5-26

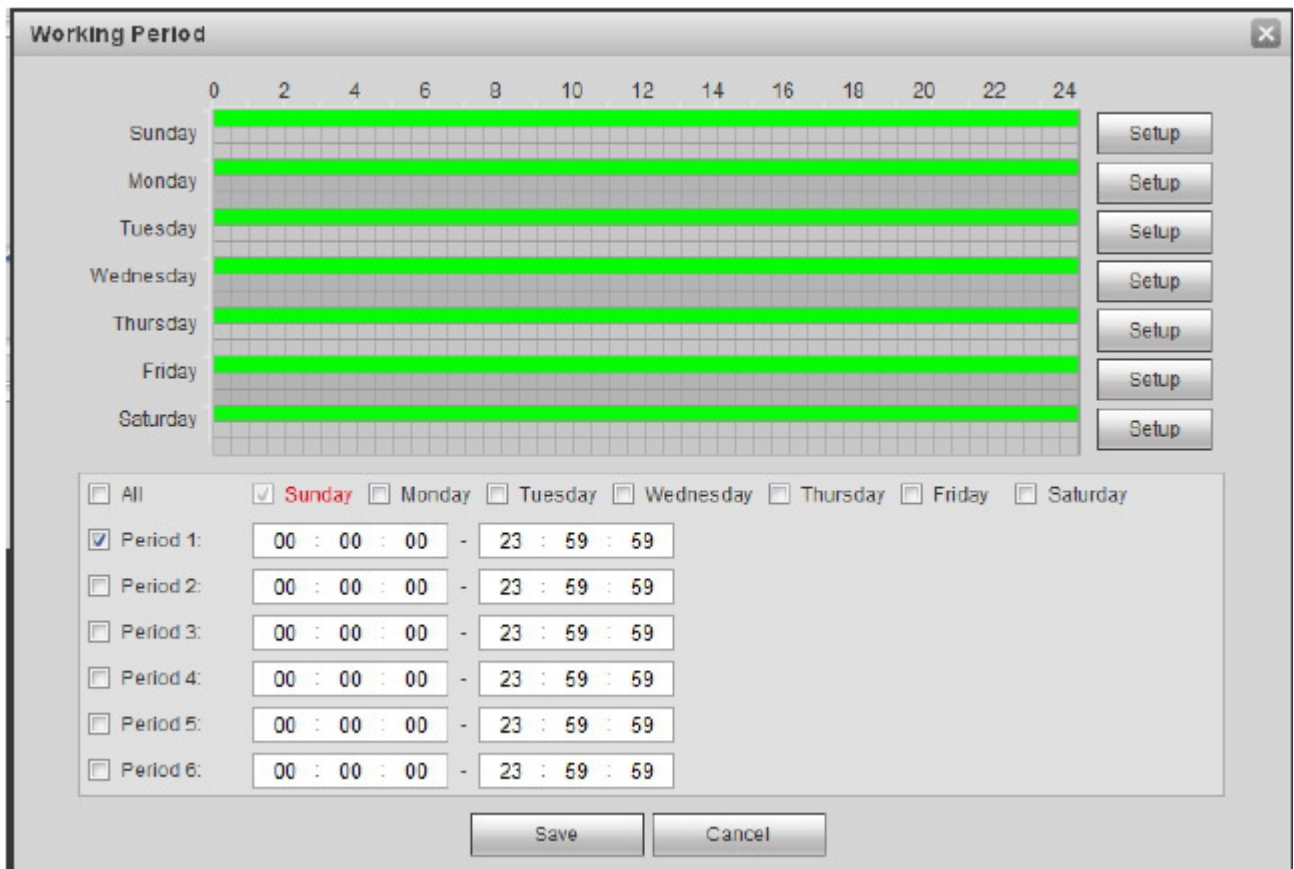

Figure 5-27

Please refer to the following sheet for detailed information.

Parameter	Function
Enable	User need to check the box to enable motion detection function.
Working Period	Here user may set arm/disarm period. Click on set button to open period setup menu. There are six periods every day for setup and user must check box in front of each period to enable it. Note: Period setup can be done by dragging mouse while not release left mouse.
Anti-dither	System only memorizes one event during the anti-dither period. The value ranges from 0s to 100s.
Area	Here user may set motion detection region and its sensitivity and area. (The higher the sensitivity is, the easier to trigger motion detect; the smaller the area, the easier to trigger motion detect.) The default covers all regions. User must click on save before enabling user setup.
Record	Check it and so when alarm occurs, system will auto record. User shall set record period in Storage>Schedule and select auto record in record control interface.
Record Delay	System can delay the record for specified time after alarm ended. The value ranges from 10s to 300s.
Relay out	Enable alarm activation function. User need to select alarm output port so that system can activate corresponding alarm device when alarm occurs.
Alarm Delay	System can delay the alarm output for specified time after alarm ended. The value ranges from 10s to 300s.
Send Email	If user enabled this function, System can send out email to alert user when alarm occurs and ends. User can set email address in Network>SMTP.
Snapshot	User need to check the box here so that system can backup motion detection snapshot file. User shall set snapshot period in Storage>Schedule.

See Figure 5-28.

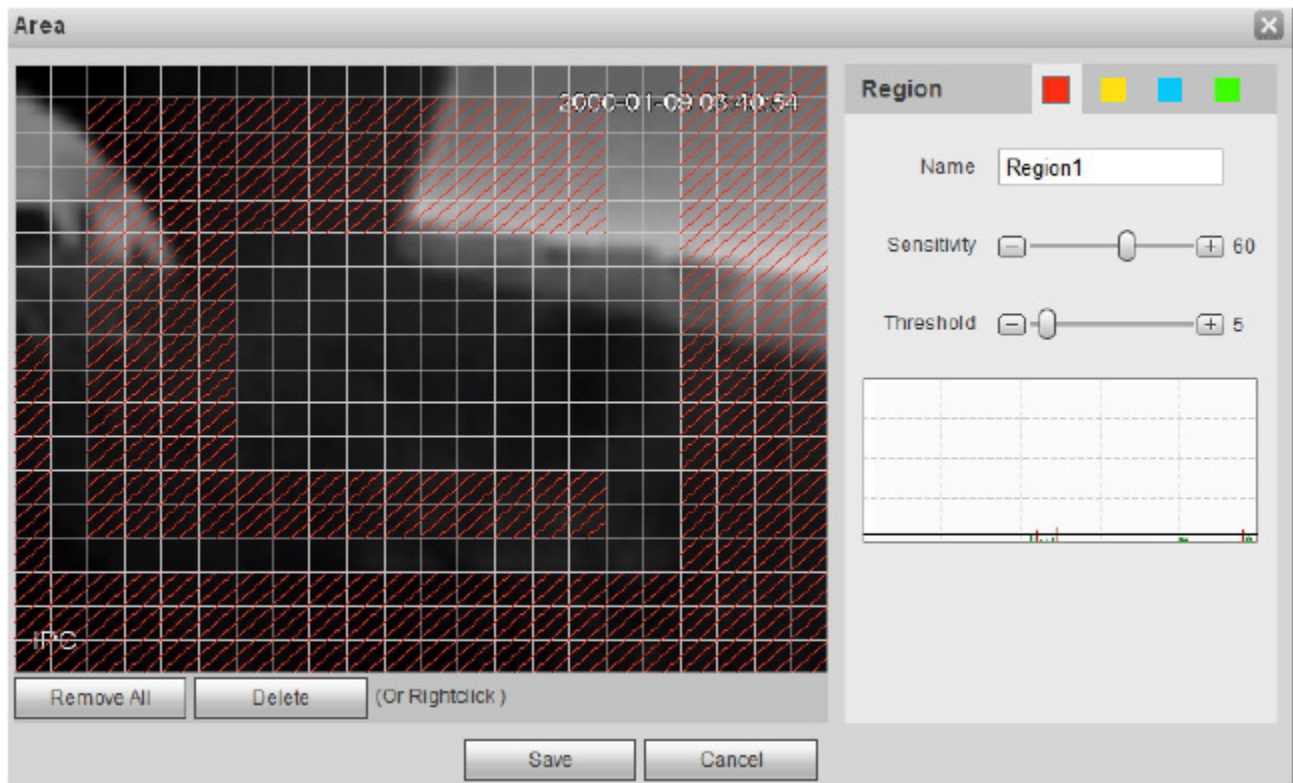

Figure 5-28

Different colors represent different areas. Each area can set different detection zones. Detection zone can be irregular and discontinuous. If device monitoring zone is large, user can sub-divide the area into several zones for better motion detect.

Please refer to the following sheet for detailed information.

Parameter	Function
Name	Default area name includes Region0, Region1, Region2, Region3 and custom.
Sensitivity	It is sensitivity of brightness as motion detection is more possible to be trigger with high sensitivity. User may set up to four areas. The range is 0~100. The recommended value is 30~70.
Area threshold	It is to check target object area related to detection area. The lower the area threshold, the easier to trigger motion detection. User may set up to four areas. The range is 0~100. The recommended value is 0~10.
Waveform	Red means motion detect is triggered. Green means motion detect is not triggered.

Delete all	Clear all areas.
Delete	Delete selected area.

5.3.2 IVS Analyze

Note:

Some models don't support IVS Analyze function. See Figure 5-29.

5.3.2.1 Tripwire

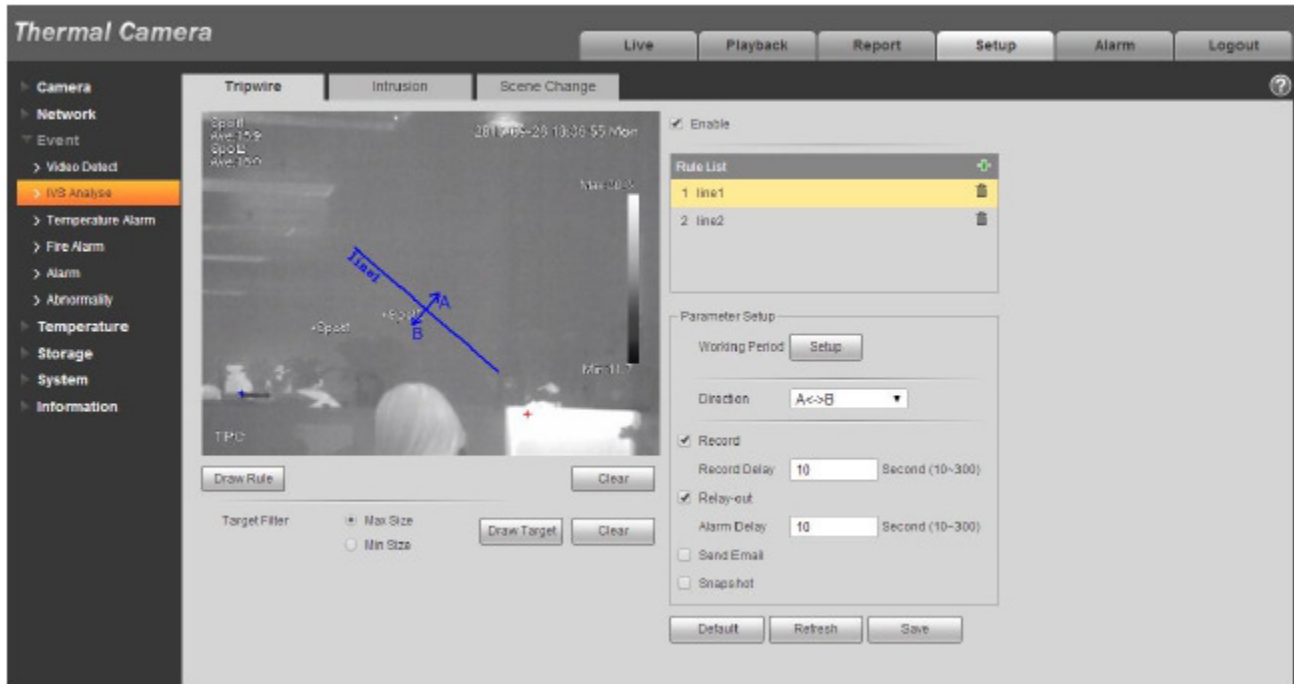

Figure 5-29

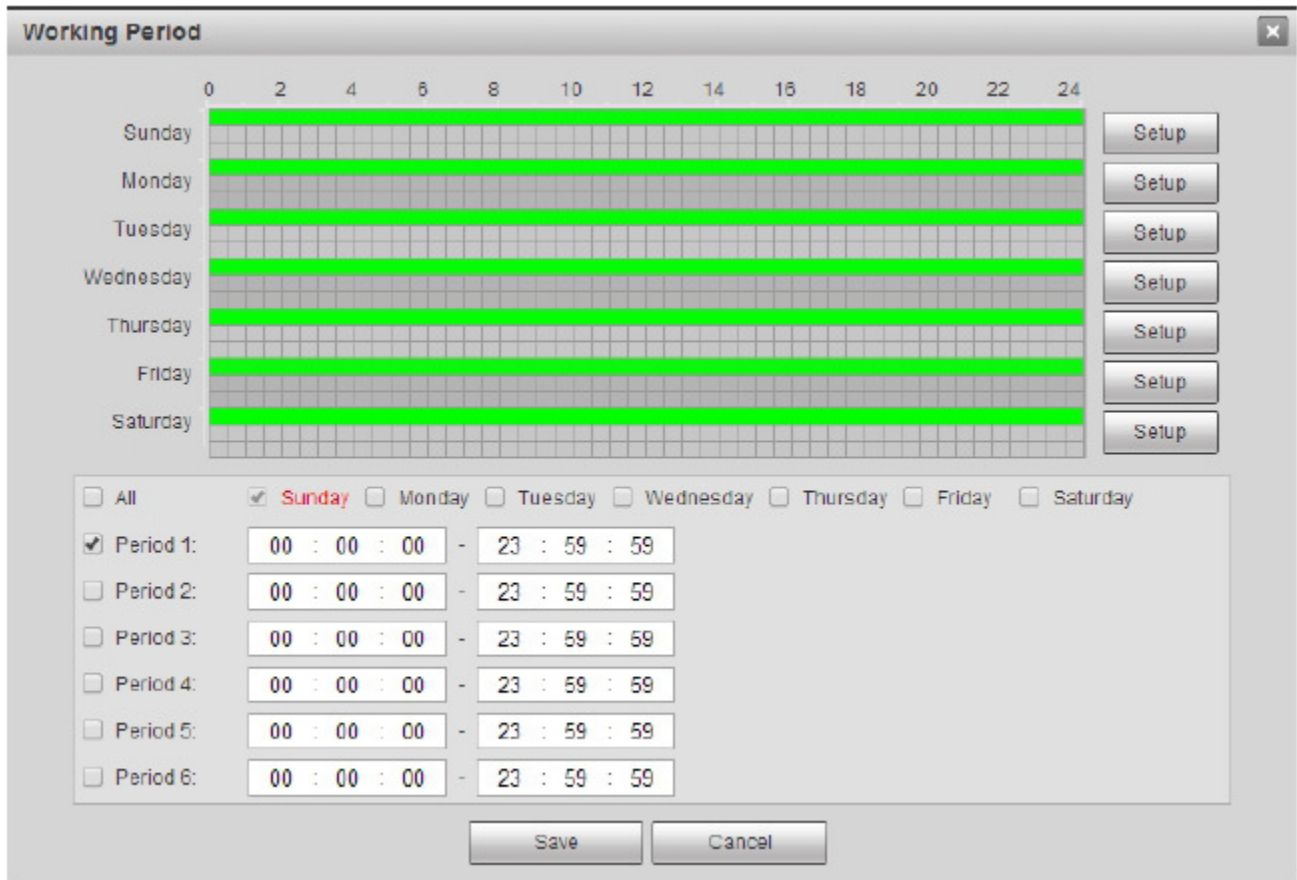

Figure 5-30

Parameter	Note
Enable	Check it to enable tripwire rule.
Add/Clear	Click to add rule. Click to clear rule.
Draw Rule	Click it to draw corresponding rule in the image.
Clear	Click it to clear the drawn rules.
Target Filter	After selecting max size or min size, click button to draw the size model of filter target aiming at this rule; click button to clear the target filter model which has been drawn.

Parameter	Note
Working Period	<ul style="list-style-type: none"> ● It is to set the alarm period, it can enable alarm event only in the set time range. ● There are six periods every day for setup and user must check box in front of each period to enable it. ● Select days (Sunday by default, if select all the week, then it means applying the setup into the whole week; user may also check the box in front of the day and make setting for some days separately). ● Click "OK" button after completing setup, go back to motion detect setting page, click "OK" button to finish working period setup of motion detect <p>Note: Period setup can be done by dragging mouse while not releasing left mouse.</p>
Direction	It is to select tripwire direction, user may select A->B、 B->A、 A<->B
Record	Check it and so when alarm occurs, system will auto record. User shall set record period in Storage>Schedule and select auto record in record control interface.
Record Delay	System can delay the alarm record for specified time after alarm ended. The value ranges from 10s to 300s.
Relay out	Check it to enable alarm activation output port, the system can activate corresponding alarm output device when alarm occurs.
Alarm Delay	System can delay the alarm output for specified time after alarm ended. The value ranges from 10s to 300s.
Send Email	If user enabled this function, System can send out email to alert user when alarm occurs. User can set his email address in Network>SMTP.
Snapshot	User need to check the box here so that system can auto alarm snapshot when alarm occurs. User shall set snapshot period in Storage>Schedule.

5.3.2.2 Intrusion

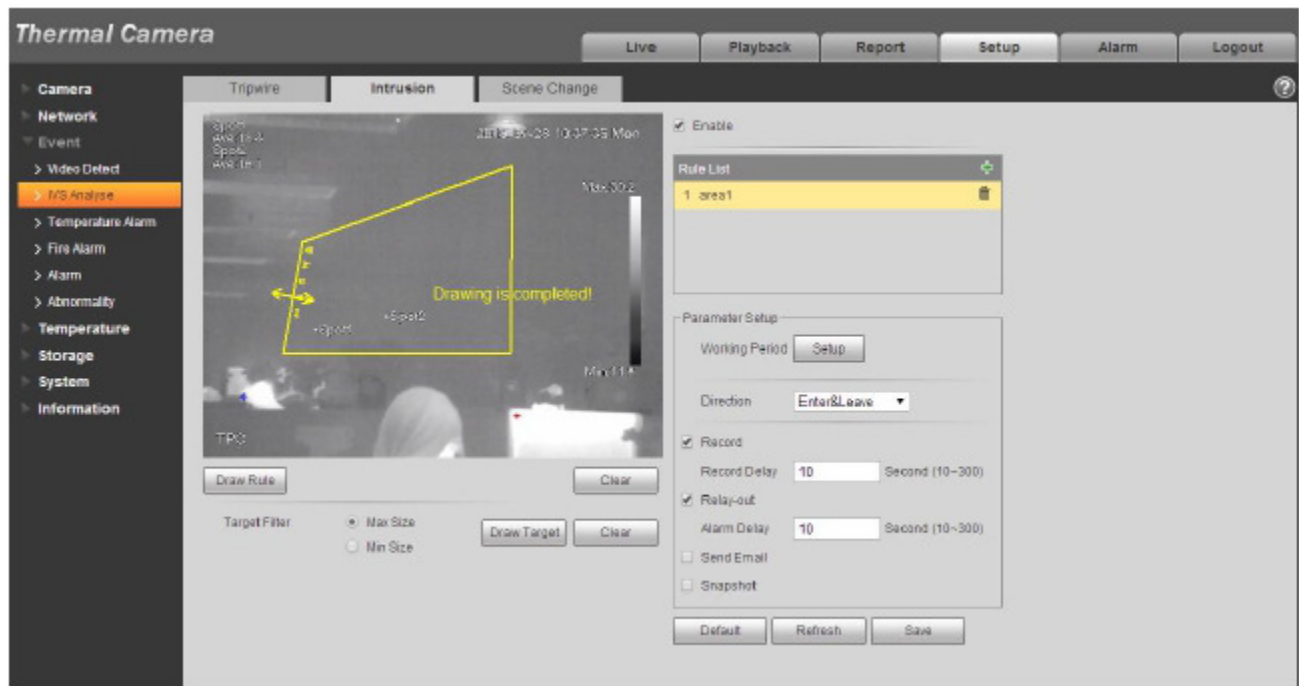

Figure 5-31

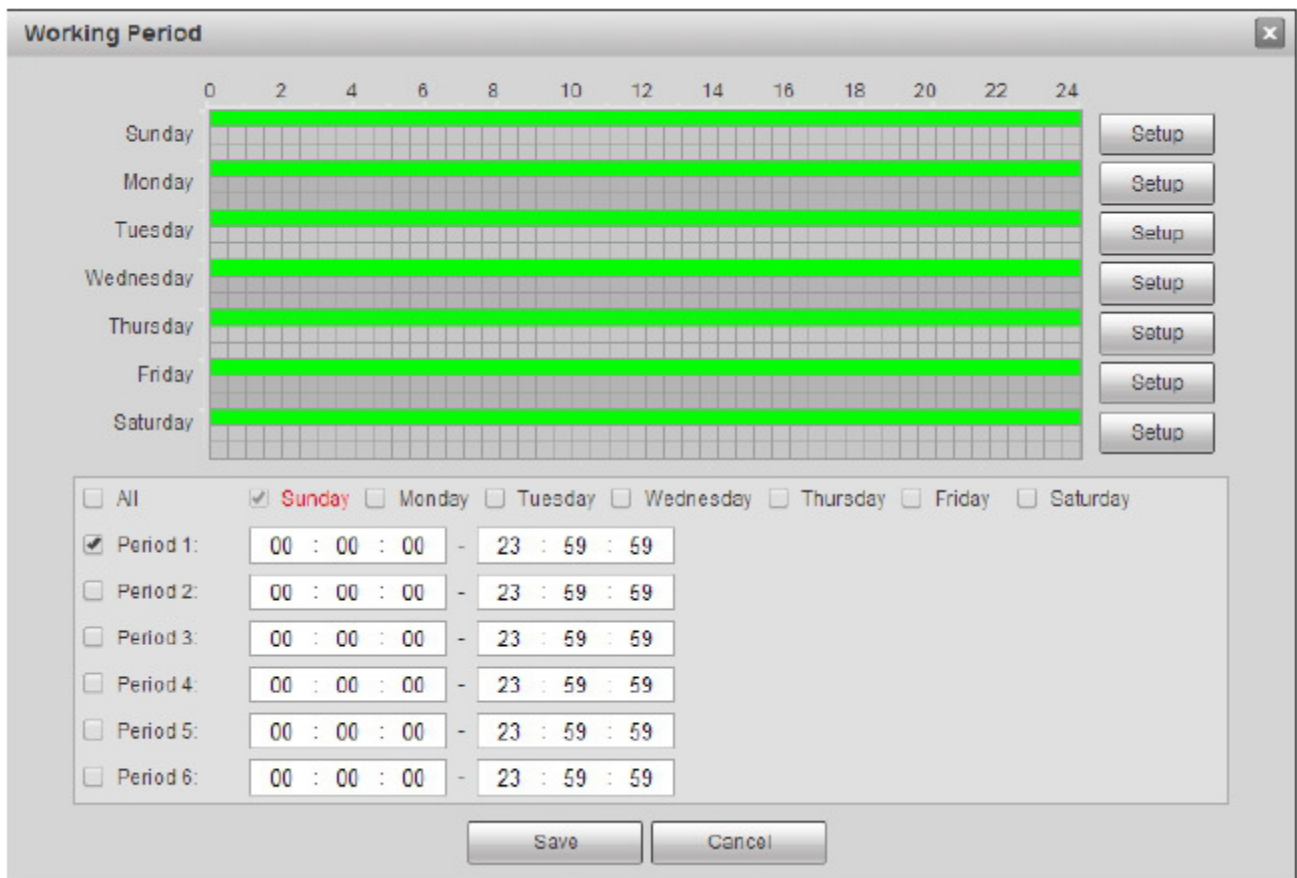





Figure 5-32

Parameter	Note
Enable	Check it to enable intrusion.
Add/Clear	Click  to add rule. Click  to clear rule.
Draw Rule	Click it to draw corresponding rule in the image.
Clear	Click it to clear the drawn rules.
Target Filter	After selecting max size or min size, click button  to draw the size model of filter target aiming at this rule; click button  to clear the target filter model which has been drawn.

Parameter	Note
Working Period	<ul style="list-style-type: none"> ● It is to set the alarm period, it can enable alarm event only in the set time range. ● There are six periods every day for setup and user must check box in front of each period to enable it. ● Select days (Sunday by default, if select all the week, then it means applying the setup into the whole week; user may also check the box in front of the day and make setting for some days separately). ● Click "OK" button after completing setup, go back to motion detect setting page, click "OK" button to finish working period setup of motion detect <p>Note: Period setup can be done by dragging mouse while not releasing left mouse.</p>
Direction	It is to select intrusion direction; user may select Enter, Leave, Enter & Leave.
Record	Check it and so when alarm occurs, system will auto record. User shall set record period in Storage>Schedule and select auto record in record control interface.
Record Delay	System can delay the alarm record for specified time after alarm ended. The value ranges from 10s to 300s.
Relay out	Check it to enable alarm activation output port, the system can activate corresponding alarm output device when alarm occurs.
Alarm Delay	System can delay the alarm output for specified time after alarm ended. The value ranges from 10s to 300s.
Send Email	If user enabled this function, System can send out email to alert user when alarm occurs. User can set his email address in Network>SMTP.
Snapshot	User need to check the box here so that system can auto alarm snapshot when alarm occurs. User shall set snapshot period in Storage>Schedule.

5.3.2.3 Scene Change



Figure 5-33

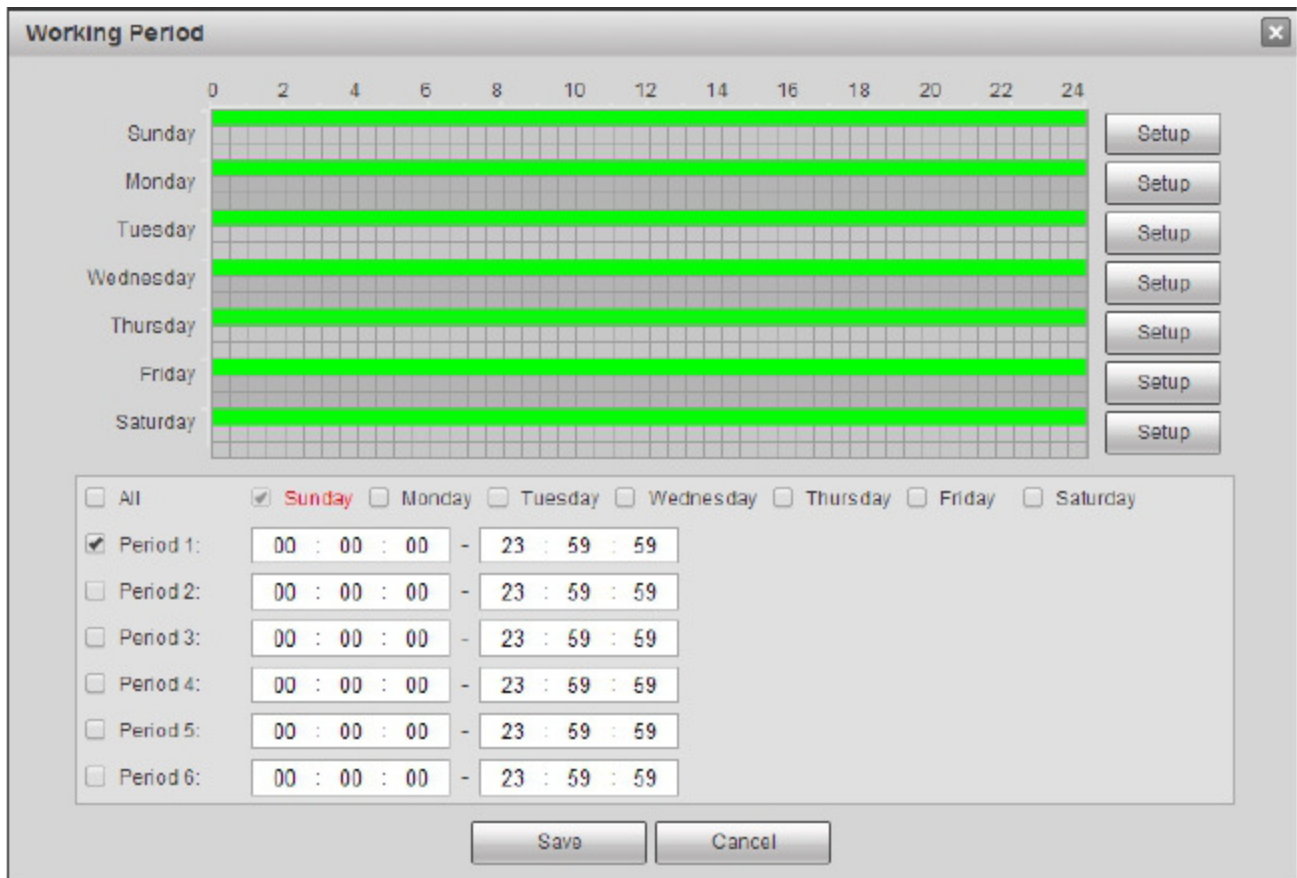

Figure 5-34

Parameter	Note
Enable	Check it to enable scene change function.
Working Period	<ul style="list-style-type: none"> ● It is to set the alarm period, it can enable alarm event only in the set time range. ● There are six periods every day for setup and user must check box in front of each period to enable it. ● Select days (Sunday by default, if select all the week, then it means applying the setup into the whole week; user may also check the box in front of the day and make setting for some days separately). ● Click "OK" button after completing setup, go back to motion detect setting page, click "OK" button to finish working period setup of motion detect <p>Note: Period setup can be done by dragging mouse while not releasing left mouse.</p>
Record	Check it and so when alarm occurs, system will auto record. User shall set record period in Storage>Schedule and select auto record in record control interface.
Record Delay	System can delay the alarm record for specified time after alarm ended. The value ranges from 10s to 300s.

Parameter	Note
Relay out	Check it to enable alarm activation output port, the system can activate corresponding alarm output device when alarm occurs.
Alarm Delay	System can delay the alarm output for specified time after alarm ended. The value ranges from 10s to 300s.
Send Email	If user enabled this function, System can send out email to alert user when alarm occurs. User can set his email address in Network>SMTP.
Snapshot	User need to check the box here so that system can auto alarm snapshot when alarm occurs. User shall set snapshot period in Storage>Schedule.

5.3.3 Temperature Alarm

Note:

Some models don't support temperature alarm function.



Figure 5-35

Parameter	Note
Enable	User need to check the box to enable alarm activation

Parameter	Note
Working Period	<ul style="list-style-type: none"> ● It is to set the alarm period, it can enable alarm event only in the set time range. ● There are six periods every day for setup and user must check box in front of each period to enable it. ● Select days (Sunday by default, if select all the week, then it means applying the setup into the whole week; user may also check the box in front of the day and make setting for some days separately). ● Click "OK" button after completing setup, go back to motion detect setting page, click "OK" button to finish working period setup of motion detect <p>Note: Period setup can be done by dragging mouse while not releasing left mouse.</p>
Anti-Dither	System only memorizes one event during the anti-dither period. The value ranges from 0s to 100s.
Record	Check it and so when alarm occurs, system will auto record. User shall set record period in Storage>Schedule and select auto record in record control interface.
Record Delay	System can delay the alarm record for specified time after alarm ended. The value ranges from 10s to 300s.
Relay out	Check it to enable alarm activation output port, the system can activate corresponding alarm output device when alarm occurs.
Alarm Delay	System can delay the alarm output for specified time after alarm ended. The value ranges from 10s to 300s.
Send Email	If user enabled this function, System can send out email to alert user when alarm occurs. User can set his email address in Network>SMTP.
Snapshot	User need to check the box here so that system can auto alarm snapshot when alarm occurs. User shall set snapshot period in Storage>Schedule.

5.3.4 Fire Alarm

Note:

Some models don't support fire alarm function.

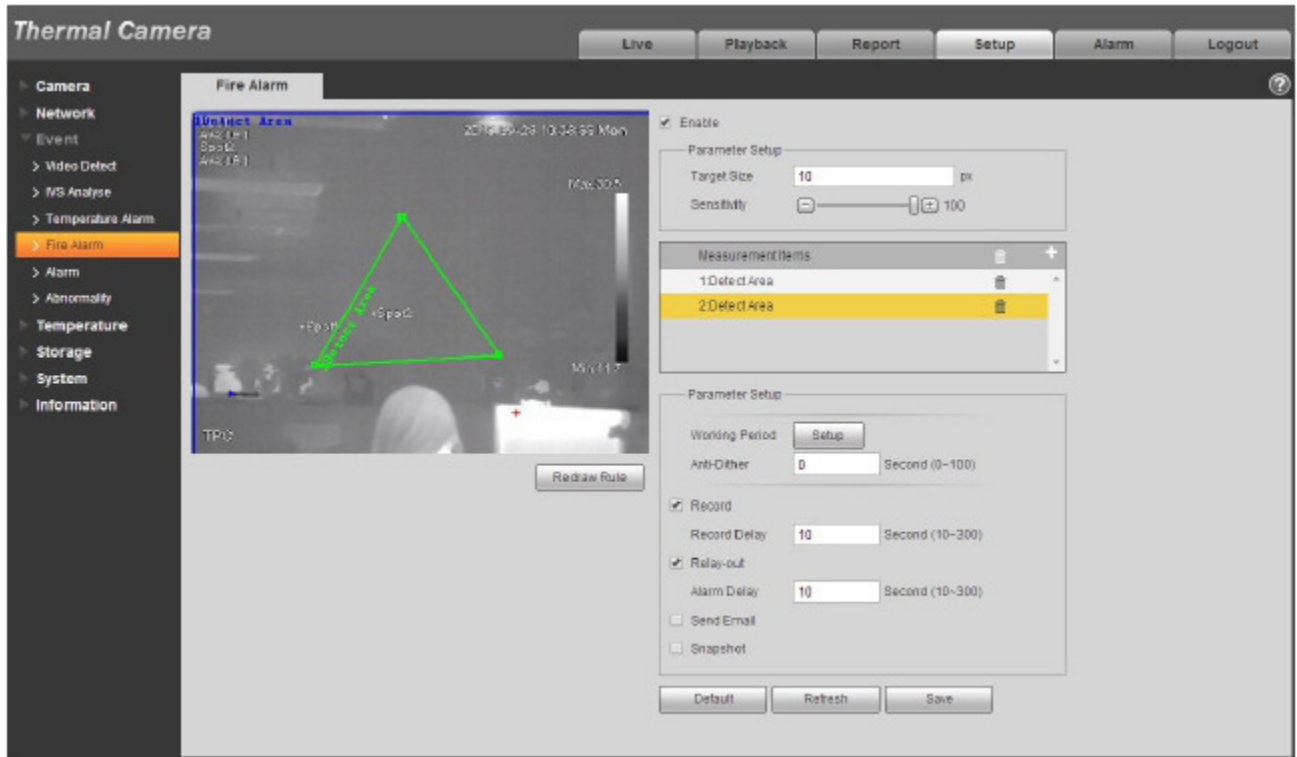
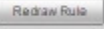



Figure 5-36

Parameter	Note
Enable	User need to check the box to enable local config function.
Target Size	It is to the minimum target which can be recognized by fire alarm, it will generate alarm when exceeding target pixel.
Sensitivity	It is to set the alarm sensitivity, ranging from 1 to 100. The higher the sensitivity is, the easier it will generate alarm, but it may generate false alarm.
Redraw Rule	Click  to redraw the corresponding rules.
Measurement Items	Click  to add new area, click the corresponding  to delete the measurement item.

Parameter	Note
Working Period	<ul style="list-style-type: none"> ● It is to set the alarm period, it can enable alarm event only in the set time range. ● There are six periods every day for setup and user must check box in front of each period to enable it. ● Select days (Sunday by default, if select all the week, then it means applying the setup into the whole week; user may also check the box in front of the day and make setting for some days separately). ● Click "OK" button after completing setup, go back to motion detect setting page, click "OK" button to finish working period setup of motion detect <p>Note: Period setup can be done by dragging mouse while not releasing left mouse.</p>
Anti-Dither	System only memorizes one event during the anti-dither period. The value ranges from 0s to 100s.
Record	Check it and so when alarm occurs, system will auto record. User shall set record period in Storage>Schedule and select auto record in record control interface.
Record Delay	System can delay the alarm record for specified time after alarm ended. The value ranges from 10s to 300s.
Relay out	Check it to enable alarm activation output port, the system can activate corresponding alarm output device when alarm occurs.
Alarm Delay	System can delay the alarm output for specified time after alarm ended. The value ranges from 10s to 300s.
Send Email	If user enabled this function, System can send out email to alert user when fire alarm occurs. User can set his email address in Network>SMTP.
Snapshot	User need to check the box here so that system can auto alarm snapshot when alarm occurs. User shall set snapshot period in Storage>Schedule.

5.3.5 Alarm

Please note some series products do not support this function.

5.3.5.1 Alarm



Figure 5-37

Parameter	Note
Enable	Check the box to enable relay activation.
Working Period	<ul style="list-style-type: none"> ● It is to set the alarm period, it can enable alarm event only in the set time range. ● There are six periods every day for setup and user must check box in front of each period to enable it. ● Select days (Sunday by default, if select all the week, then it means applying the setup into the whole week; user may also check the box in front of the day and make setting for some days separately). ● Click “OK” button after completing setup, go back to motion detect setting page, click “OK” button to finish working period setup of motion detect <p>Note: Period setup can be done by dragging mouse while not releasing left mouse.</p>
Anti-Dither	System only memorizes one event during the anti-dither period. The value ranges from 0s to 100s.
Sensor Type	Able to set NC and NO.
Record	System auto activates motion detection channel to record once alarm occurs (working with motion detection function). Meanwhile users have to set record period of alarm in “Storage>Schedule” and select auto record in the record control interface.
Record Delay	System can delay the record for specified time after alarm ended. The value ranges from 10s to 300s.

Parameter	Note
Relay-out	Enable alarm activation function. User need to select alarm output port so that system can activate corresponding alarm device when alarm occurs.
Alarm Delay	System can delay the alarm output for specified time after alarm ended. The value ranges from 10s to 300s.
Send Email	After this function is enabled, system can send out email to alert user when alarm occurs and ends. Users can set his own email address in "Network Setting > SMTP".
Snapshot	After user enabled snapshot, the system will automatically snapshot if alarm occurs. Meanwhile user have to set snapshot period of alarm in the "storage>Schedule".

5.3.6 Abnormity

Abnormity includes No SD Card, Capacity Warning, SD Card Error, Disconnection, IP Conflict and Unauthorized Access.

Note:

Only device with SD card function has these three statuses: No SD card, capacity warning, and SD card error.

Device without SD card function does not have the above three statuses. See Figure 5-38.

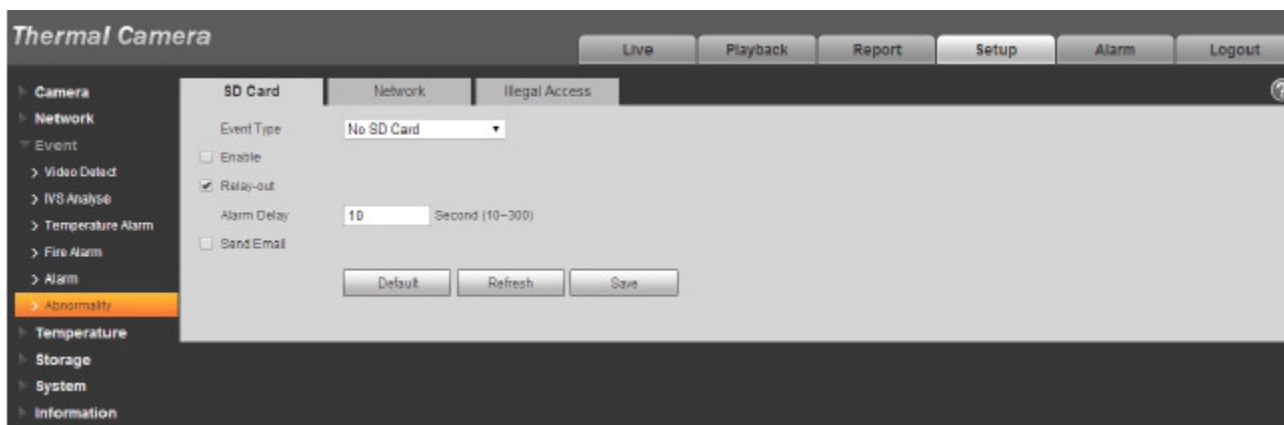

Figure 5-38

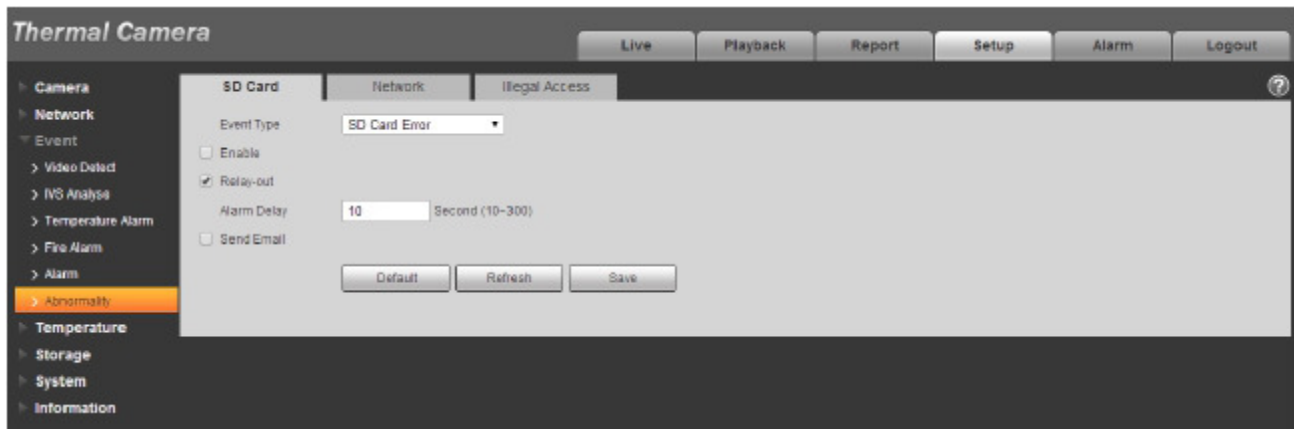

Figure 5-39



Figure 5-40

Please refer to the following sheet for detailed information.

Parameter	Function
Event Type	Three event types to cause SD card abnormality: No SD card, SD card capacity warning, and SD card error.
Enable	Check to alarm when SD card is abnormal.
Relay-out	Check to enable relay-out alarm.
Relay out delay	The alarm output can delay for the specified time after alarm stops. The value ranges from 10s to 300s. Note: No SD card, capacity warning, SD card error, relay-out delay all start from alarm occurs.

Parameter	Function
Send email	After user enabled this function, the system can send out email to alarm the specified user. This function is invalid when network is offline or IP conflict occurs.
SD Card Capacity Limit	User can set SD card capacity that is left free. When SD card space left is smaller than this limit, alarm occurs.

When device is offline or IP conflicts, the abnormal alarm is similar with case of SD card error.



Figure 5-41

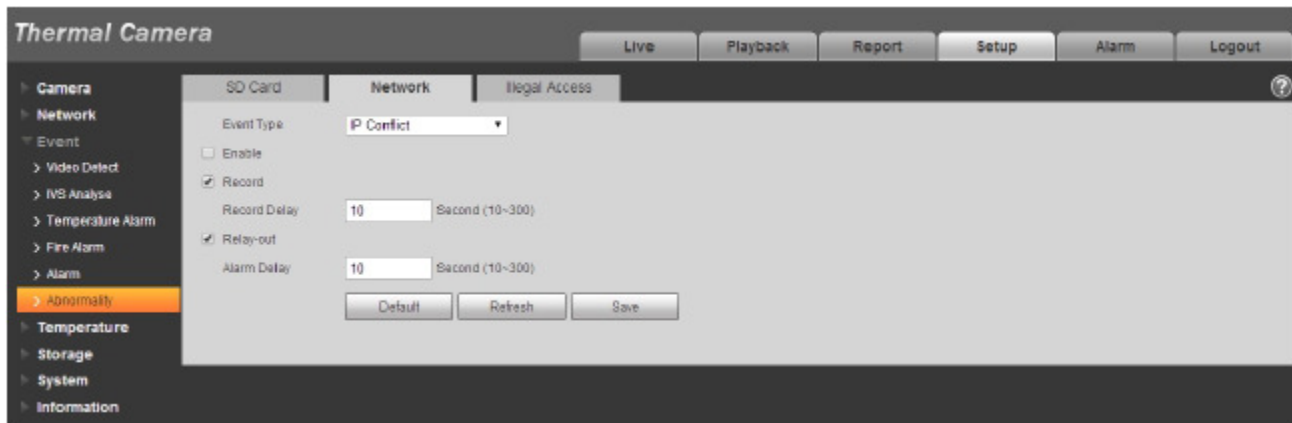

Figure 5-42

When login password keep been wrong for a few times, unauthorized access alarm occurs. This operation is similar to SD card error. Allow login error times as when it exceeds this limit, user account will be locked.



Figure 5-43

5.4 Temperature

Note:

Some models don't support temperature measurement function.

5.4.1 Rule Setup

5.4.1.1 Parameter Config

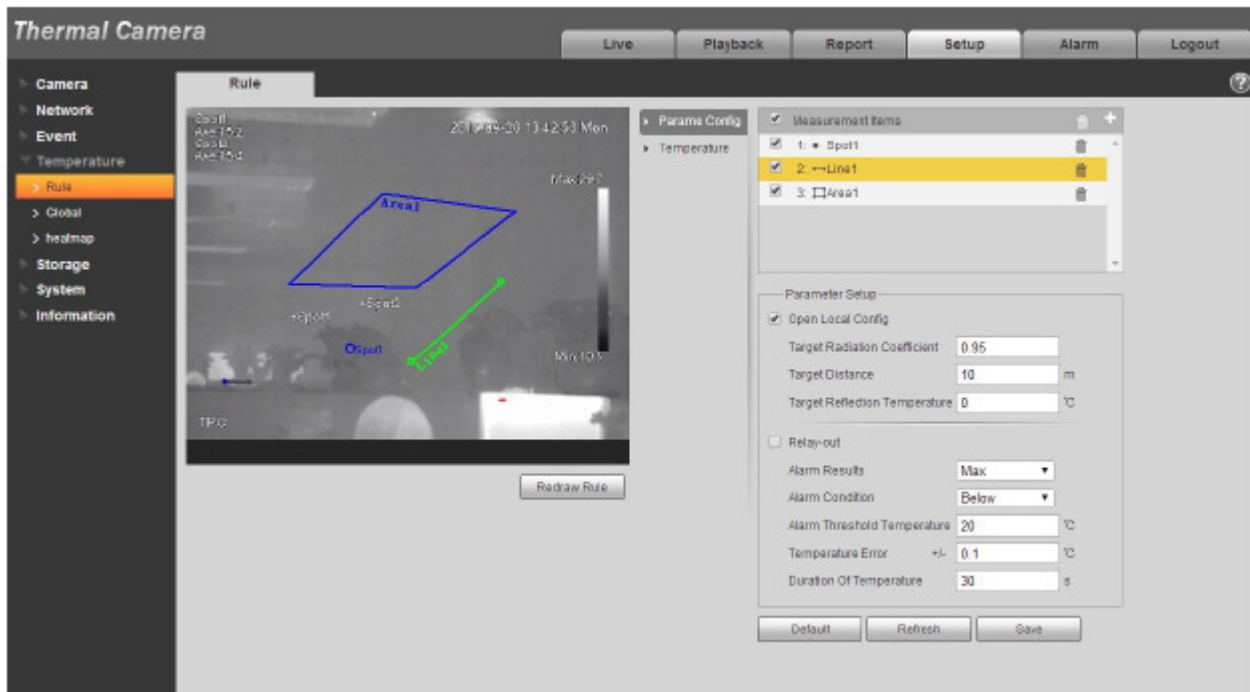





Figure 5-44

Parameter	Note
Measurement Items	Click  to add new spot, line and area, click corresponding  to delete the measurement item.
Open Local Config	Check it to enable local config function.
Target Radiation Coefficient	It is to set the target emissivity, 0~1 optional.
Target Distance	It is to set the distance between camera and target, 0~1000m optional.
Target Reflection Temperature	It is to set the target temperature, 0~550°C optional.
Relay Out	Check it to enable relay out function.
Alarm Result	It is to set the temperature value mode of triggering alarm. <ul style="list-style-type: none"> ● Spot: optional value ● Line: able to select max, min and average. ● Area: able to select max, min, average, standard and middle
Alarm Condition	It is to set alarm condition, optional below, match and above.
Alarm Threshold Temperature	It is to set the threshold temperature of triggering alarm, 0~550°C optional.
Temperature Error	It is to set temperature error, 0~10°C optional.
Temperature Duration	It will trigger alarm when the temperature is above the alarm threshold temperature and exceed the set duration temperature. Temperature duration 0 ~ 1000s optional.
Redraw Rule	Click  to redraw corresponding rule.

When the temperature of designated spot, line or area meets the condition of triggering alarm, it will continue to flicker to red as alarm hint in the preview interface. See Figure 4-82.

Note:

It will display alarm result in the preview interface only when check “Enable” in the “Event > Temperature Alarm” and set appropriate “Working Period”.

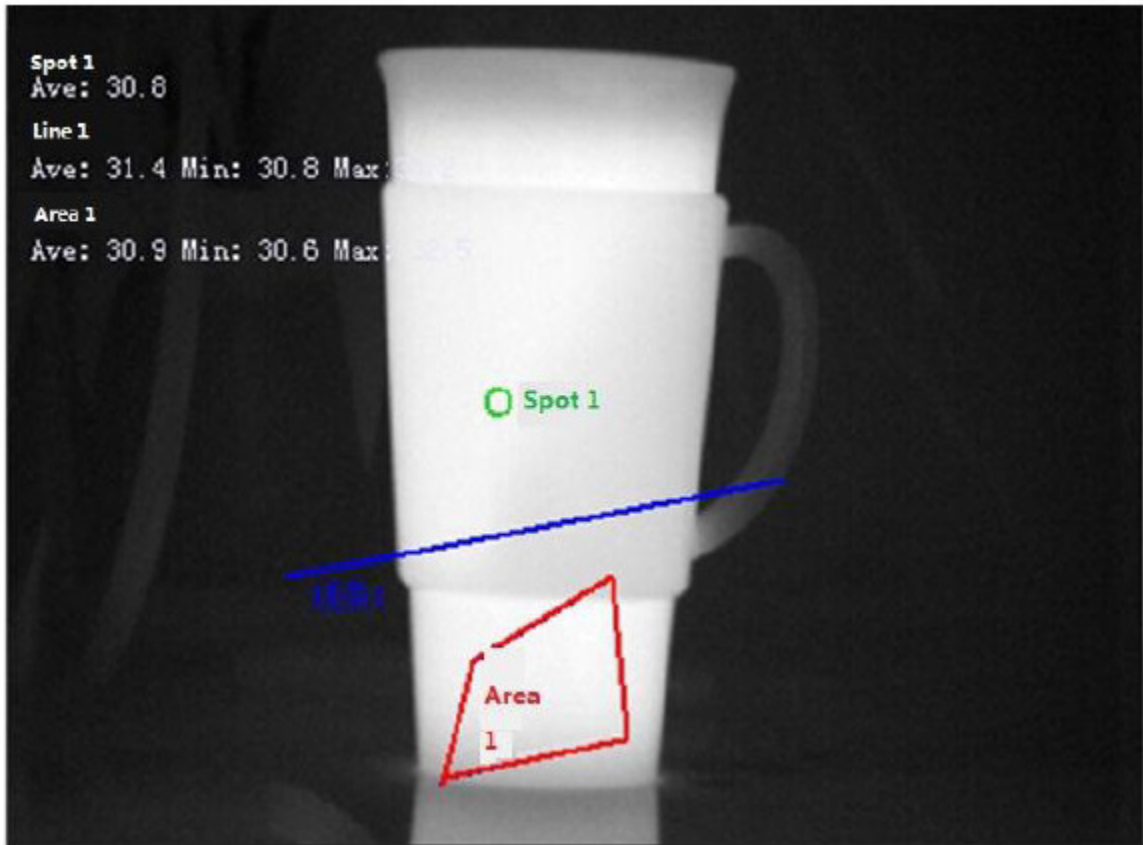

Figure 5-45

5.4.1.2 Temperature Contrast

Note:

The function is only supported by some models.

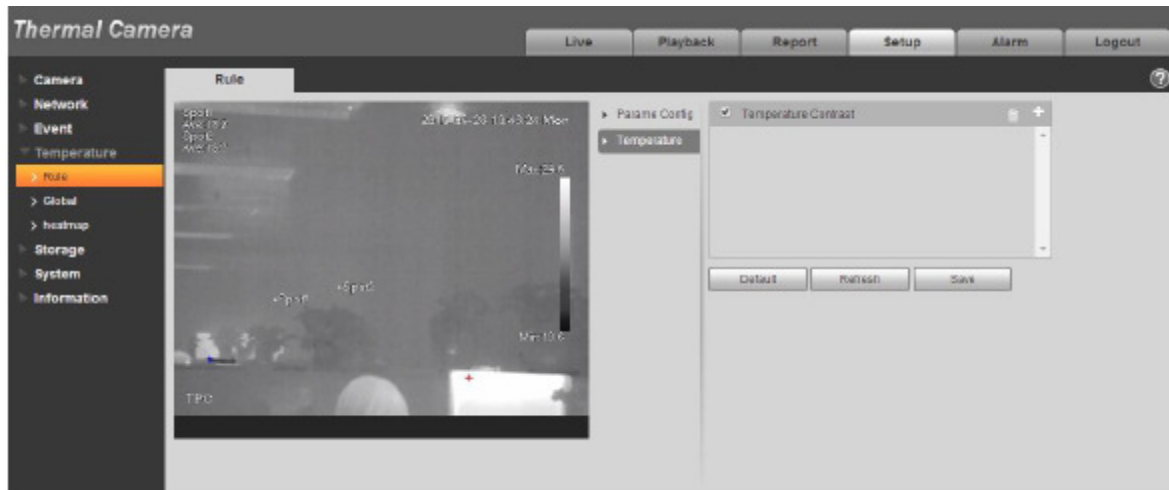



Figure 5-46

Temperature contrast function means comparing the temperature of selected spot, line or area and display the result on the preview interface, the steps are shown as follows:

Step 1 Click  to add contrast record.

Step 2 Select the target which needs to be compared, see Figure 5-47.

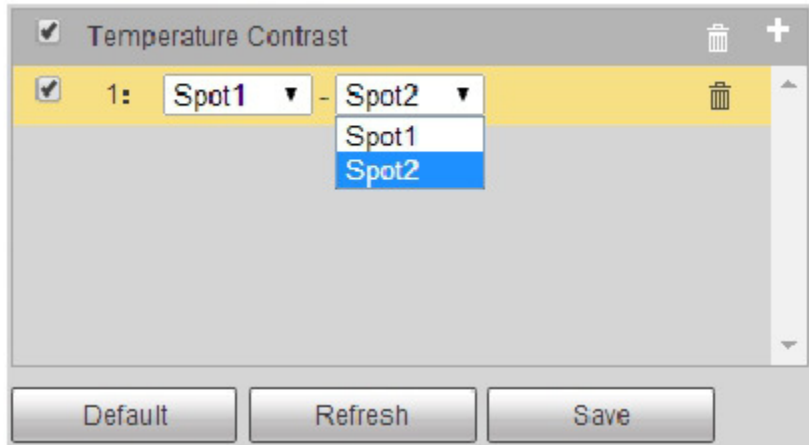

Figure 5-47

Step 3 Click  to save, then user may see the contrast result of the selected target on the left of preview interface, see Figure 5-48.



Figure 5-48

5.4.2 Global

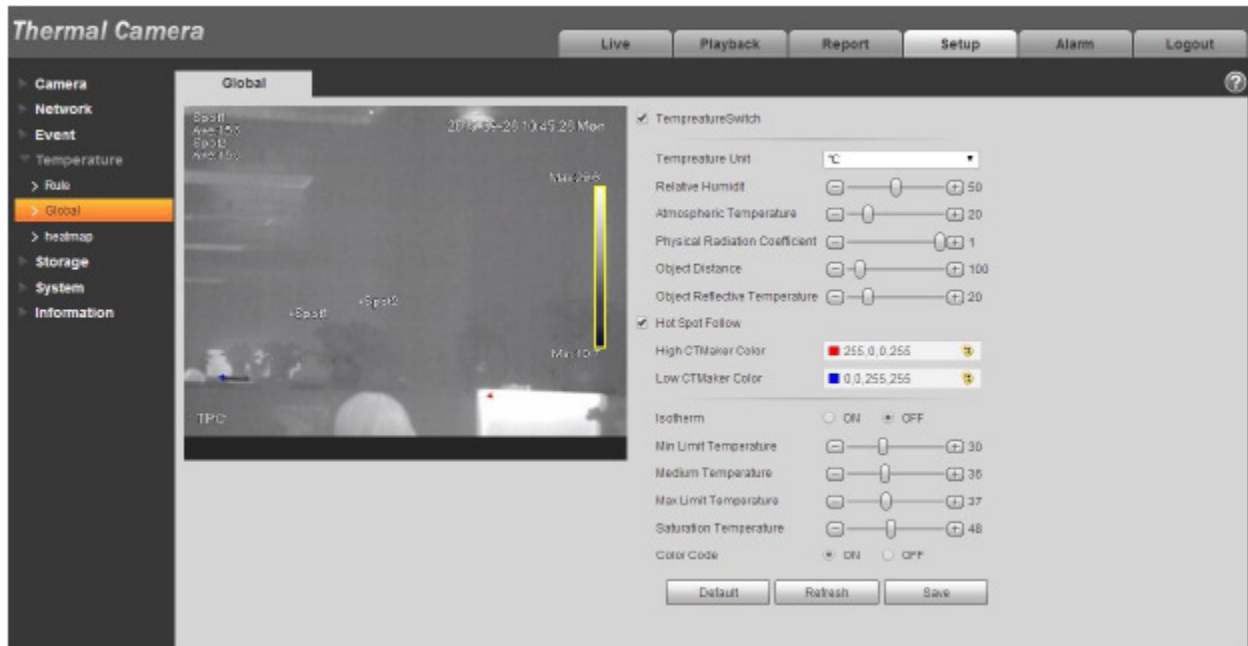

Figure 5-49

Parameter	Note
Temperature Switch	Check it to enable temperature switch function.
Temperature Unit	It is to set the displayed temperature unit, °C and F optional.
Relative Humidity	It is to set the environment relative humidity, 0~100% RH optional.
Atmospheric Temperature	It is to set environmental temperature, 0~100°C optional.
Physical Radiation Coefficient	It is to set physical radiation coefficient, 0~1 optional.
Object Distance	It is to set physical distance, 0~100m optional.
Object reflective Temperature	It is to set the object reflective temperature, 0~100°C optional.
Hot Spot Follow	Check it to enable the function of hot spot detection tracing.
High CTMaker Color	It is to set the display color of high temperature.

Parameter	Note
Low CTMaker Color	It is to set the display temperature of low temperature.
Isotherm	It is to select if enable isotherm function.
Min Temperature	It is to set min temperature. <ul style="list-style-type: none"> ● When gain mode is under low temperature mode, it is -40°C~ 160 °C optional. ● When gain mode is under high temperature mode, it is -40°C~ 600°C optional.
Medium temperature	It is to set medium temperature. <ul style="list-style-type: none"> ● When gain mode is low temperature, it is -40°C~160°C optional. ● When gain mode is high temperature, it is -40°C~600°C optional.
Max Temperature	It is to set max temperature. <ul style="list-style-type: none"> ● When gain mode is low temperature, it is -40°C~160°C optional. ● When gain mode is high temperature, it is -40°C~600°C optional.
Saturation Temperature	It is to saturation temperature. <ul style="list-style-type: none"> ● When gain mode is low temperature, it is -40°C~160°C optional. ● When gain mode is high temperature, it is -40°C~600°C optional.
Color Code	It is to select if enable color code.

5.4.2.1 Temperature Switch

Temperature switch function is mainly used to realize real-time temperature measurement aiming at some certain spot and display the temperature on the preview interface. As it is shown in Figure 5-50, when the mouse moves to one spot, it will display the temperature of the spot.

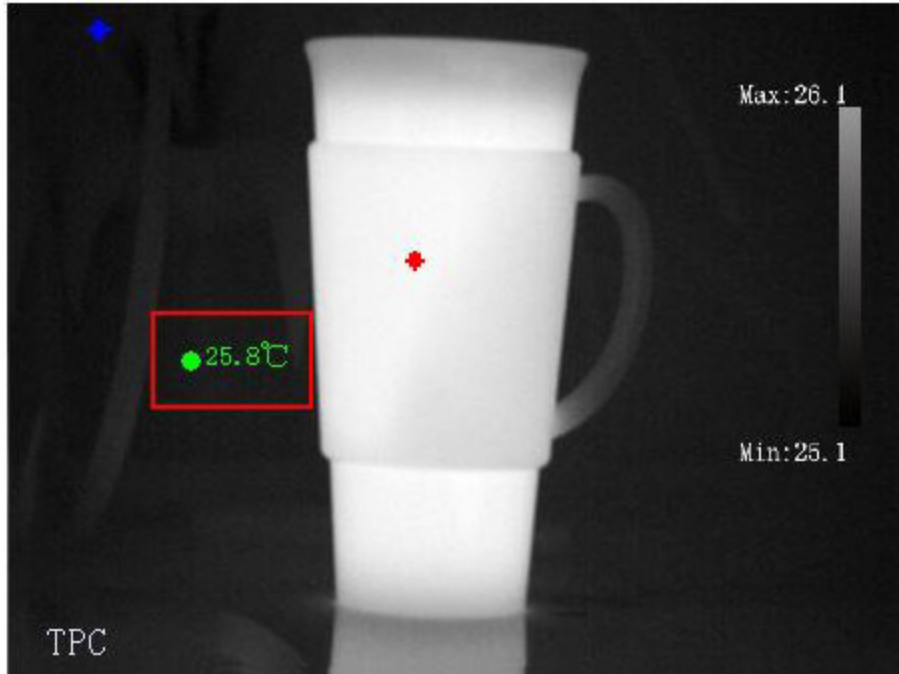

Figure 5-50

5.4.2.2 Hot Spot Follow

After enabling hot spot follow function, it will display max temperature spot and min temperature spot in the preview interface, and set the corresponding color via “High CTMaker Color” and “Low CTMaker Color” (see Figure 4-89), it will display corresponding high and low temperature color respectively, see Figure 5-51.

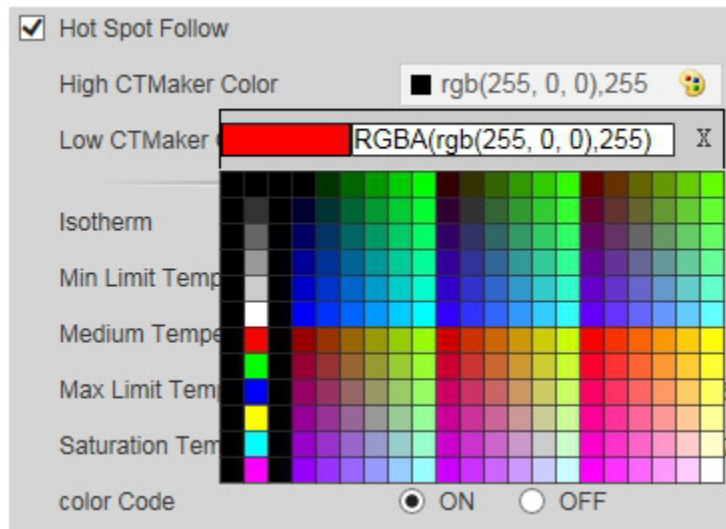

Figure 5-51

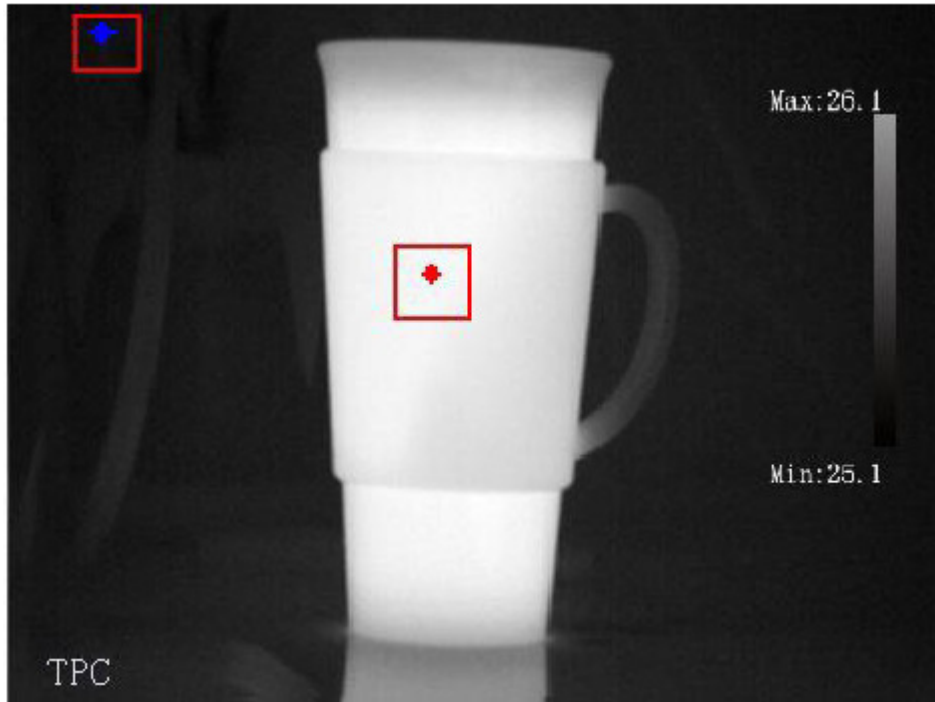

Figure 5-52

5.4.2.3 Isotherm

Isotherm function is mainly used for the highlighted object in the high brightness image, take medium temperature as the basis, max temperature and min temperature are the floating range, display the area between max temperature and min temperature with bright color, and other areas will be displayed as black, gray and white, see Figure 4-93.

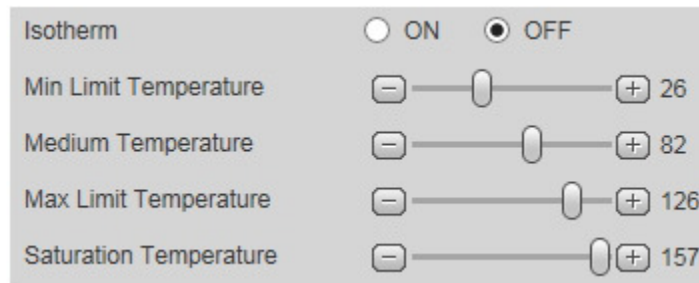

Figure 5-53

Note:

Min temperature <= Medium temperature <= Max temperature <= Saturation temperature

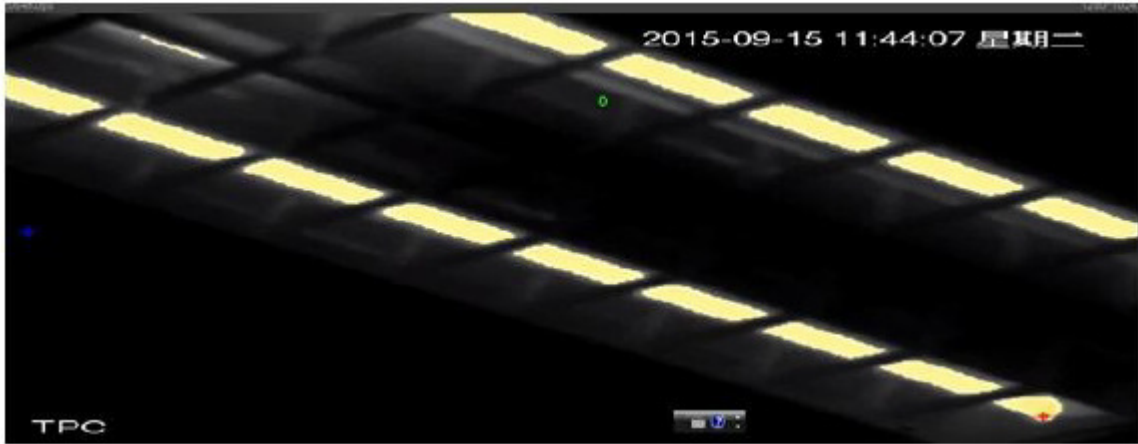

Figure 5-54

5.4.2.4 Color Code

After checking color code, it will display corresponding color code on the right of the preview interface, which can be used to present the color change between min temperature and max temperature. See Figure 5-55.

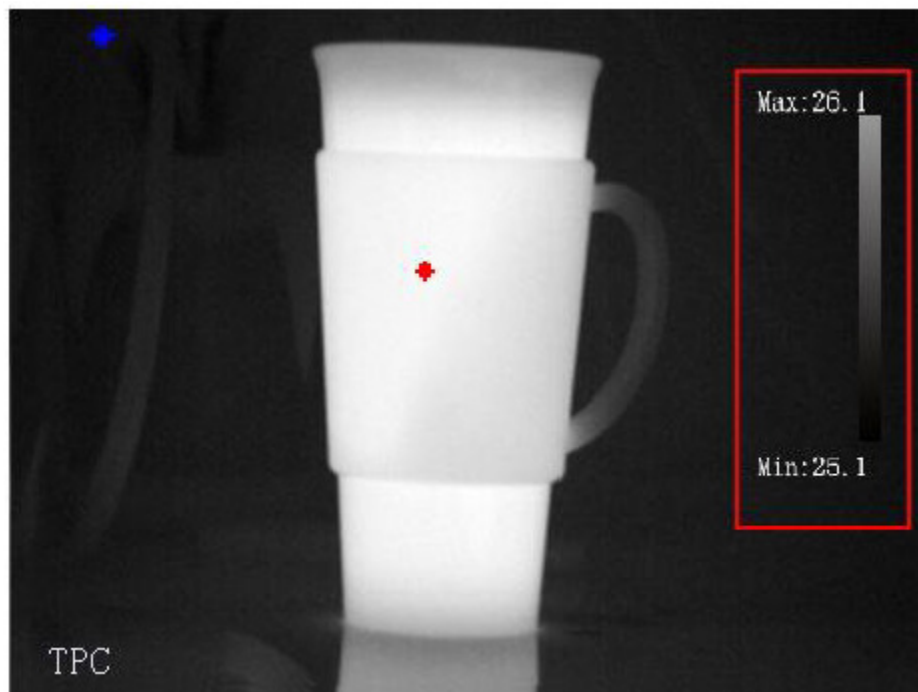

Figure 5-55

5.4.3 Heatmap

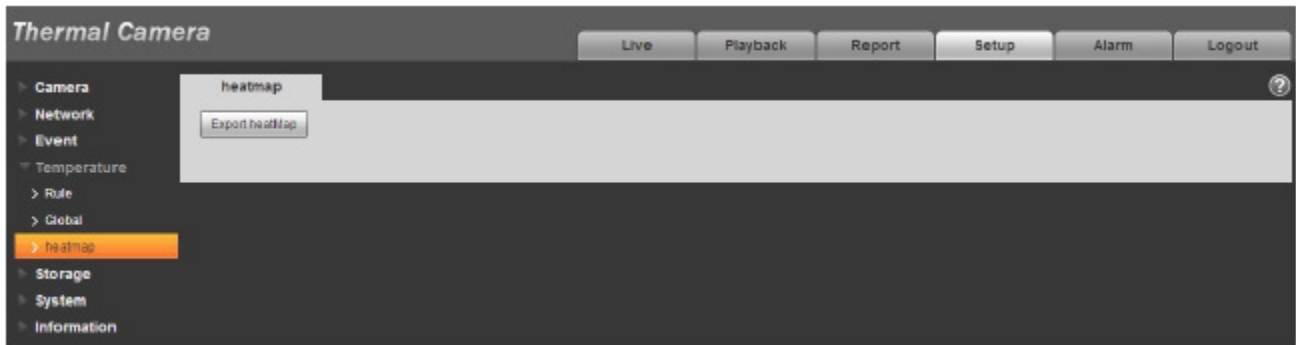

Figure 5-56

Parameter	Note
Export Heatmap	Click it to export heatmap.

5.5 Storage Management

5.5.1 Schedule

Before schedule setup, user must set record mode is auto or manual.

Note:

If record mode in record control is off, then device will not snapshot according to schedule.

5.5.1.1 Record Schedule

Record schedule steps:

Step 1. Click on Record Schedule, see Figure 5-57.

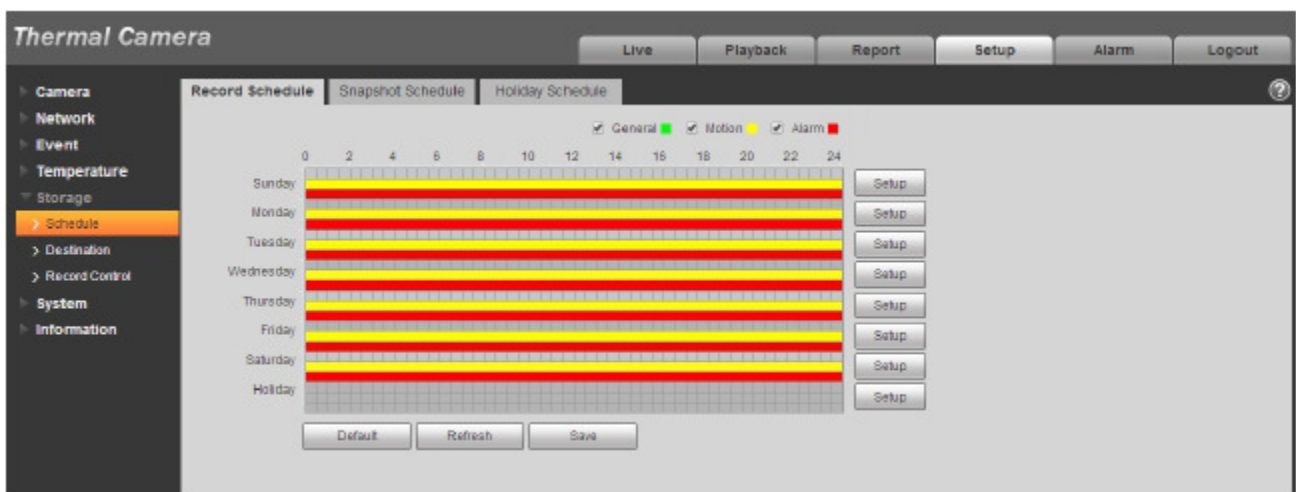

Figure 5-57

Step 2. From Monday to Sunday select record time, click on setup on the right, see Figure 5-58.

- Set period according to actual need. There are six periods available each day.
- By checking or unchecking, user may add or delete three types of record schedule: General, Motion, and Alarm.

Note:

Period setup can be done by dragging in record schedule interface while not releasing left mouse.

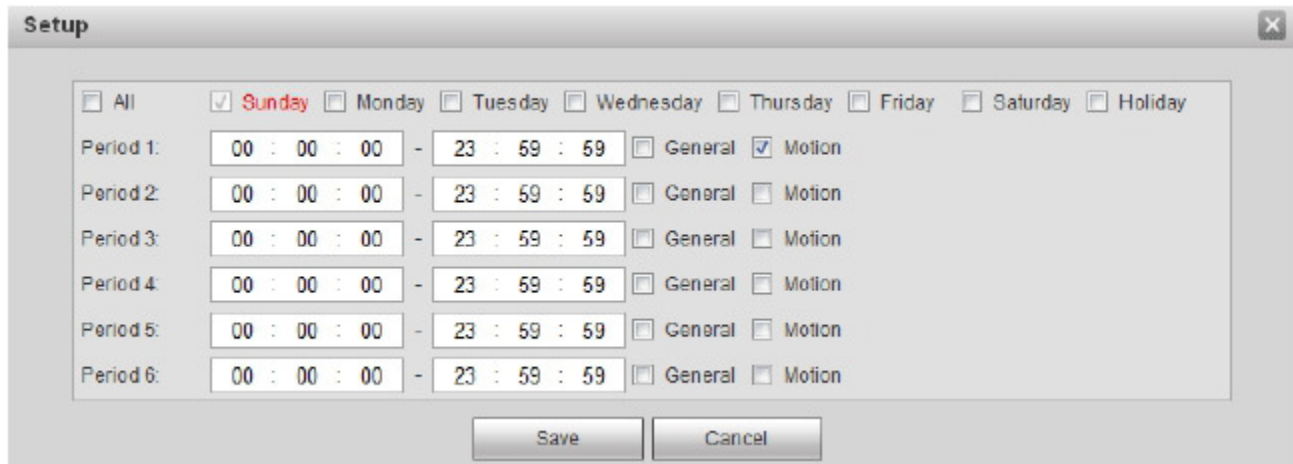

Figure 5-58

Step 3. Click on OK, return to record schedule interface. See Figure 5-59.

- Green color stands for the general record/snapshot.
- Yellow color stands for the motion detect record/snapshot.
- Red color stands for the alarm record/snapshot.

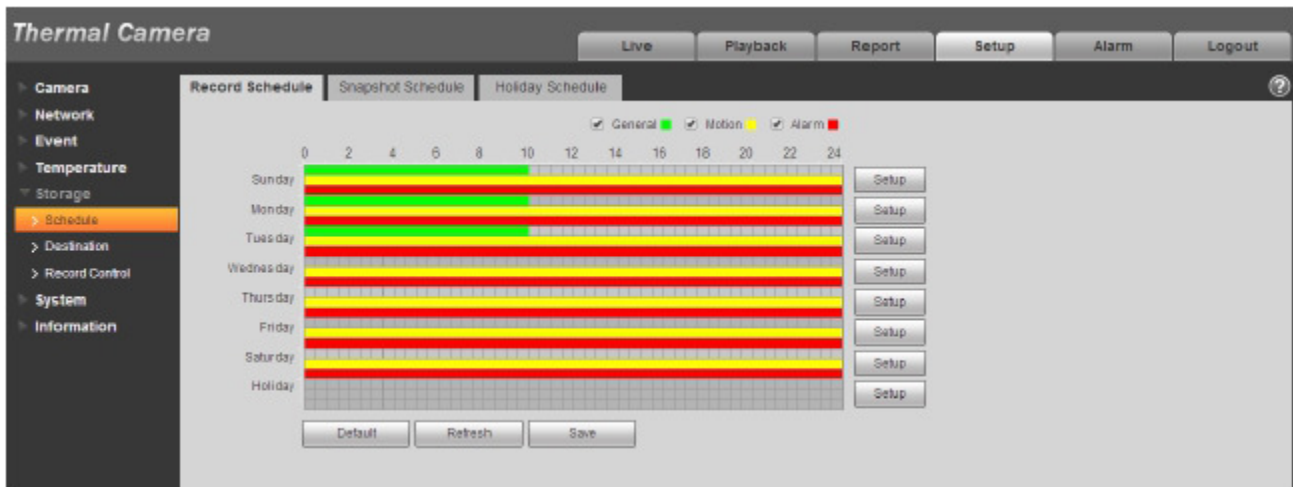

Figure 5-59

Step 4. In record schedule interface, click on OK. System prompts it is successfully saved.

5.5.1.2 Snapshot Schedule

Snapshot setup as:

Step 1. Click on Snapshot Schedule tab, see Figure .

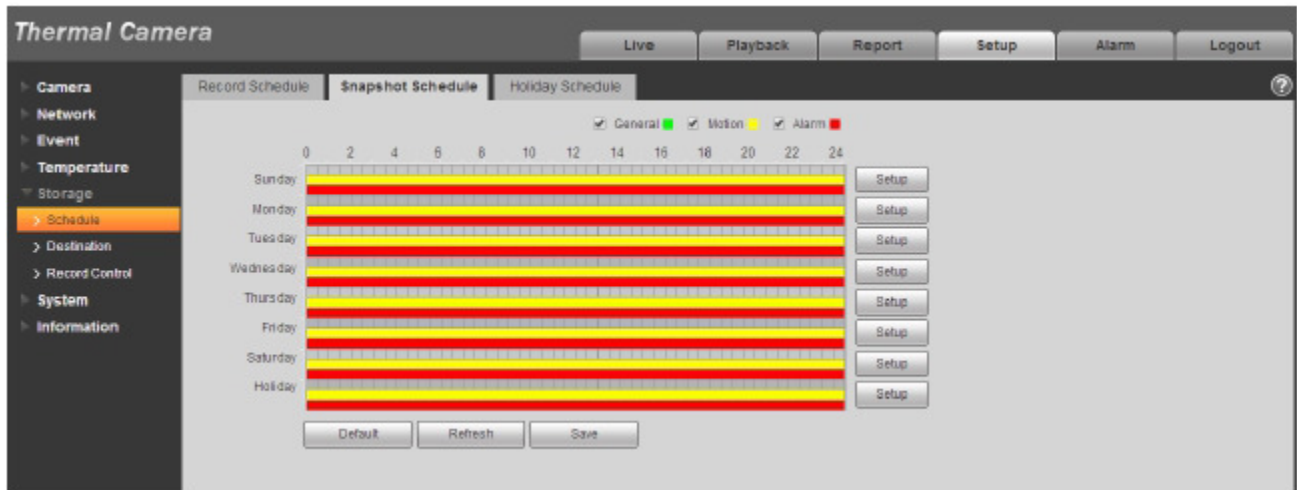

Figure 5-60

Step 2. From Monday to Sunday select snapshot time, click on setup on the right. See Figure 5-61.

- Set snapshot period according to actual need. There are six periods available each day.
- By checking or unchecking, user can add or delete three types of snapshot schedule: General, Motion and Alarm.

Note: Period setup can be done by dragging in snapshot schedule interface while not releasing left mouse.

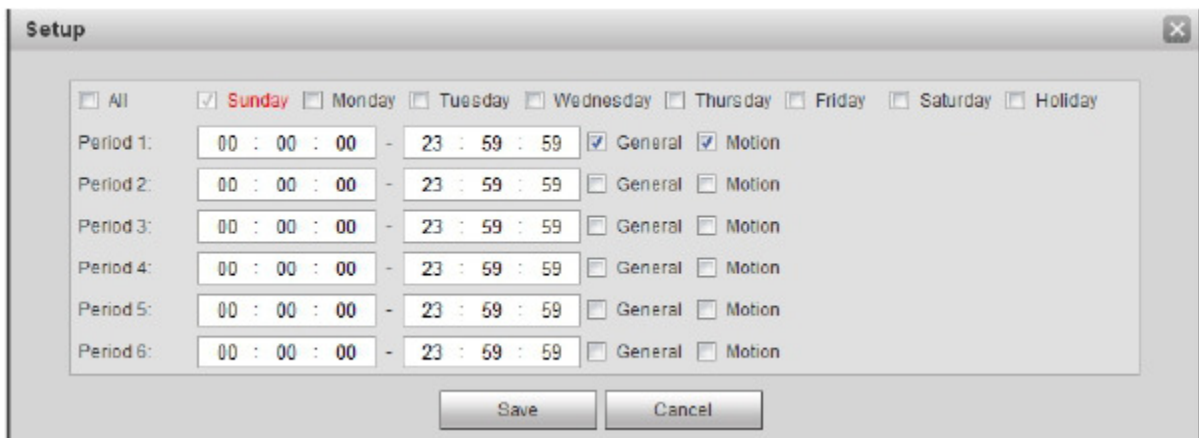

Figure 5-61

Step 3. Click on OK, return to snapshot schedule interface. See Figure 5-62.

- Green color stands for the general record/snapshot.
- Yellow color stands for the motion detect record/snapshot.
- Red color stands for the alarm record/snapshot.

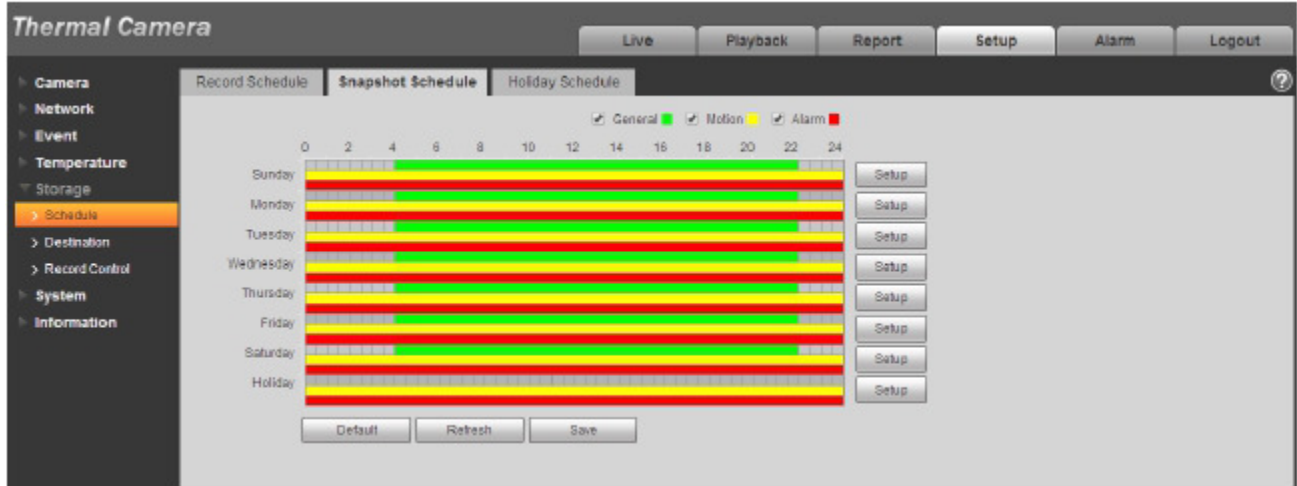

Figure 5-62

Step 5. In snapshot interface, click on OK. System prompts it is successfully saved.

5.5.1.3 Holiday Schedule

Holiday schedule can set specific date as holiday.

Step 1. Click on Holiday Schedule tab, see Figure 5-63.

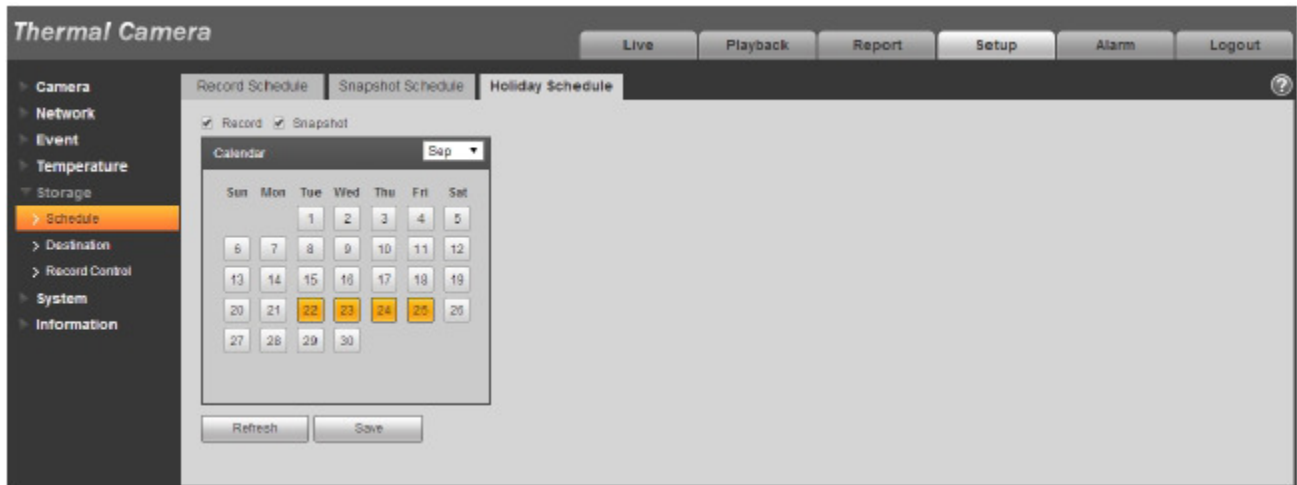

Figure 5-63

- Step 2. Select date to set as holiday. The selected date will be highlighted in yellow.
- Step 3. Check Record/Snapshot, click on Save. System prompts it is successfully saved.
- Step 4. Check Record Schedule/Snapshot Schedule interface, click on setup next to Holiday, refer to setup of Monday to Sunday.
- Step 5. Complete setup of holiday, then it records/snapshots according to date in holiday schedule.

5.5.2 Destination

5.5.2.1 Path

The destination interface is shown as in Figure 5-64.

Path can config record and snapshot storage path. There are three options: Local, FTP and NAS. User can only select one mode. System can save according to the event types. It is corresponding to the three modes (general/motion/alarm) in the Schedule interface. Please check the box to enable the save functions.

Note: Only device supports SD card has local.

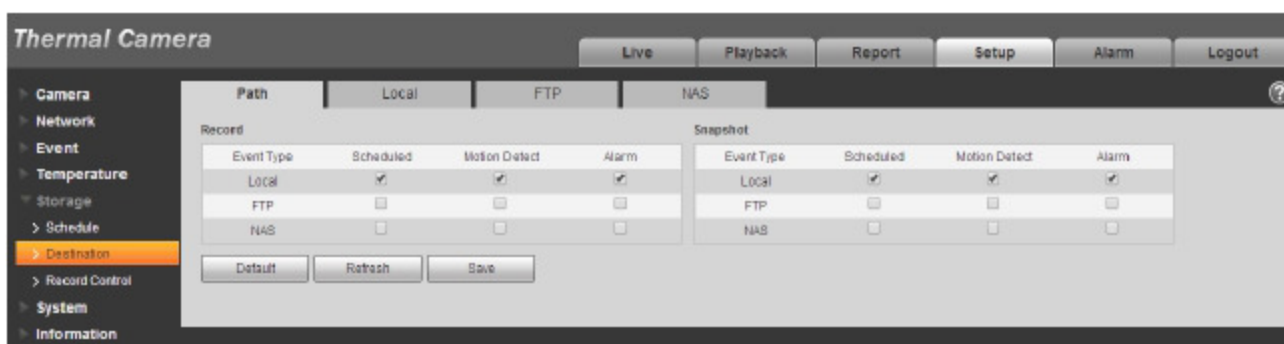

Figure 5-64

Please refer to the following sheet for detailed information.

Parameter	Function
Event Type	It includes: scheduled, motion detect and alarm.
Local	It saved in the SD card.
FTP	It saved in the FTP server.
NAS	It saved in NAS disk.

5.5.2.2 Local

The local interface is shown as in Figure 5-65.

Here user may view local Micro SD card or NAS disk information. User may also operate the read-only, write-only, hot swap and format operation.



Figure 5-65

5.5.2.3 FTP

The FTP interface is shown as in Figure 5-66.

User need to check the box to enable the FTP function. When network disconnect occurred or there is malfunction. Emergency storage can save the record/snapshot picture to the local SD card.

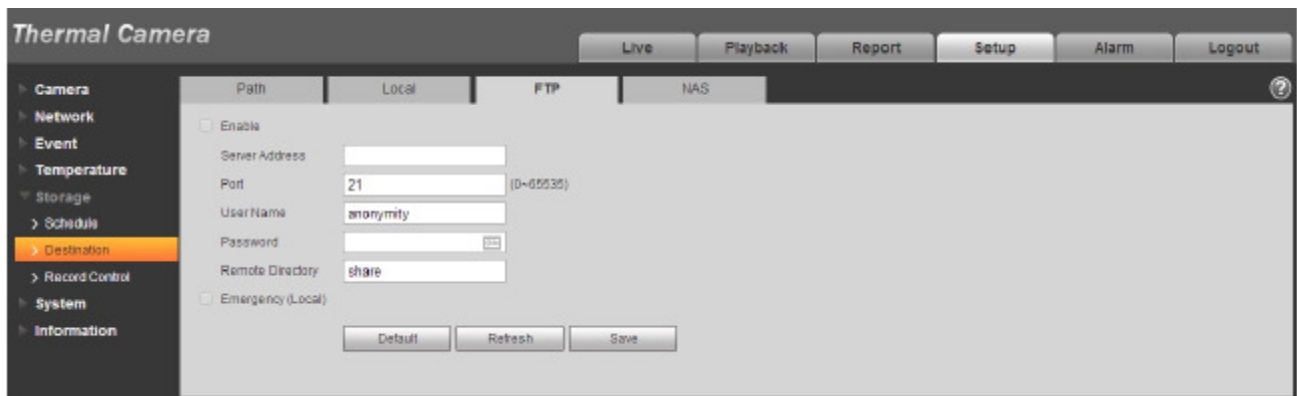

Figure 5-66

5.5.2.4 NAS

User need to check the box to enable the NAS function. Select NAS storage, fill in NAS server address and corresponding store path, then user may store video file or pictorial information in the NAS server.

Select NAS storage as to same file to NAS disk. See Figure 5-67.

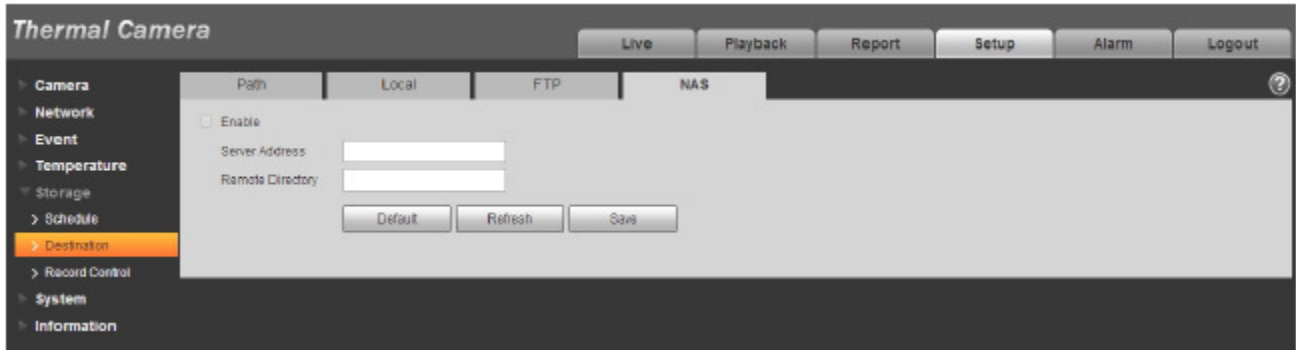

Figure 5-67

Parameter	Function
Server Address	Set IP address of NAS server.
Remote Directory	Set storage directory, videos and pictures can be stored in to corresponding server directory.

5.5.3 Record control

The record control interface is shown as in Figure 5-68.



Figure 5-68

Please refer to the following sheet for detailed information.

Parameter	Function
Pack Duration	Here user may select file size within 1min~120min. Default setup is 8 minutes.

Pre-record	<p>Please input pre-record value here.</p> <p>For example, system can record the four seconds video in the buffer. The record begins from the fifth second.</p> <p>Note:</p> <p>Configure pre-record time, when alarm or motion detection occurs, if there is no record, system will record the preceding n seconds record.</p>
Disk Full	<p>There are two options: stop recording or overwrite the previous files when HDD is full.</p> <ul style="list-style-type: none"> ● Stop: Current working HDD is overwriting or current HDD is full, it will stop record. ● Overwrite: Current working HDD is full; it will overwrite the previous file.
Record mode	There are three modes: Auto/manual/close.
Record stream	There are two options: main stream and sub stream.

5.6 System

5.6.1 General

The General interface is shown as in Figure 5-69. .

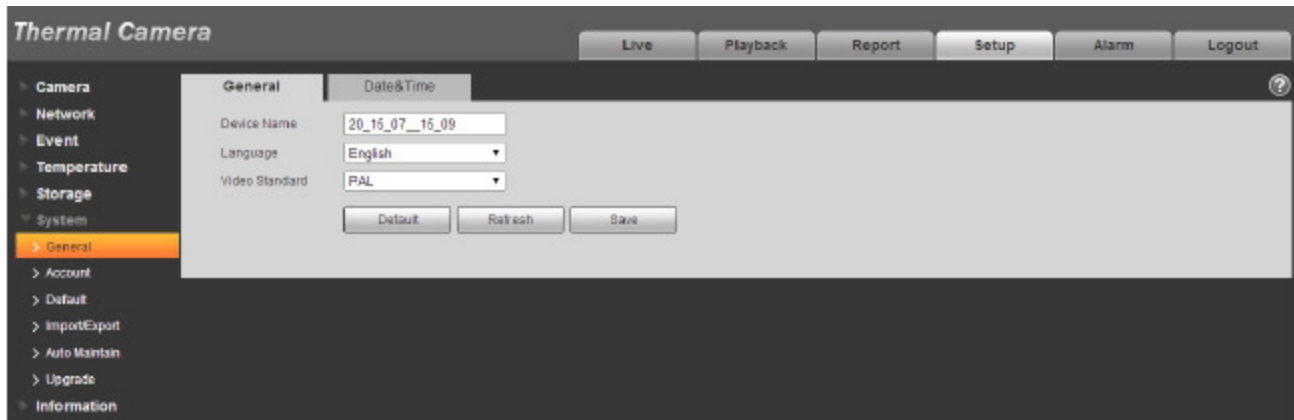

Figure 5-69

Please refer to the following sheet for detailed information.

Parameter	Function
Device Name	<p>It is to set device name.</p> <p>Note: Different devices have different names.</p>

Video Standard	This is to display video standard such as PAL or NTSC.
Language	User may select the language from the dropdown list.

The date and time interface is shown as in Figure 5-70.

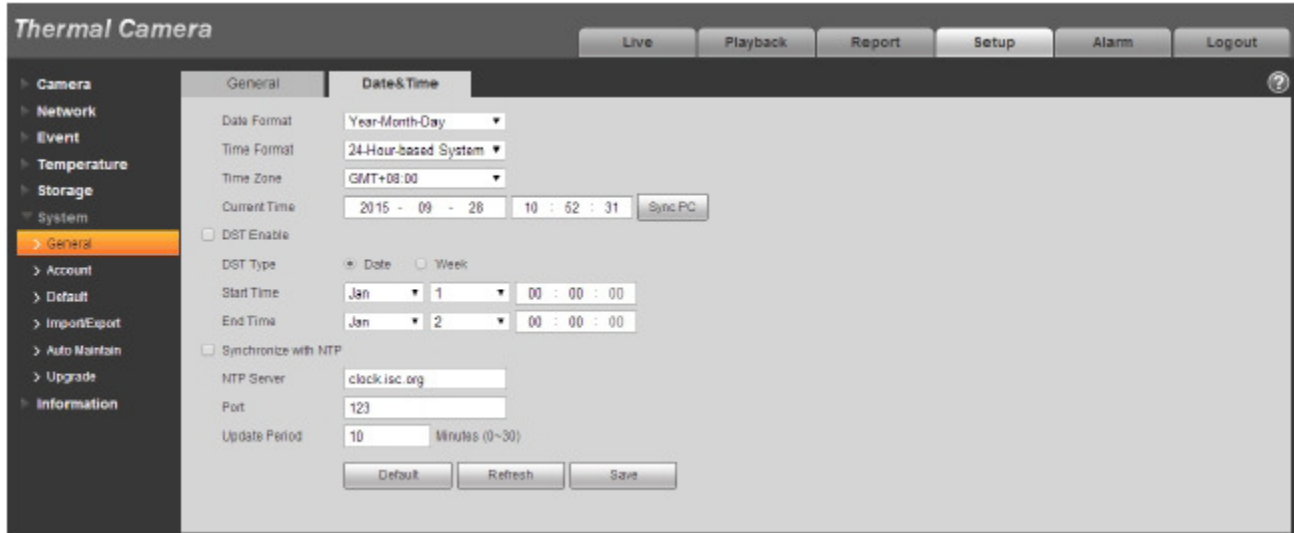

Figure 5-70

Please refer to the following sheet for detailed information.

Parameter	Function
Date format	Here user may select date format from the dropdown list.
Time Format	There are two options: 24-H and 12-H.
Time zone	The time zone of the device.
System time	It is to set system time. It becomes valid after user set.
Sync PC	User may click this button to save the system time as user PC current time.
DST	Here user may set day night save time begin time and end time. User can set according to the date format or according to the week format.
NTP	User may check the box to enable NTP function.

NTP server	User may set the time server address.
Port	It is to set the time server port.
Update period	It is to set the sync periods between the device and the time server.

5.6.2 Account

- For the character in the following user name or the user group name, system max supports 15-digits. The valid string includes: character, number, and underline.
- Password can be 0~32 characters in number and letter only. User can modify other users' password.
- The user amount is 18 and the group amount is 8 when the device is shipped out of the factory. The factory default setup includes two levels: user and admin. User may set the corresponding group and then set the rights for the respective user in the specified groups.
- User management adopts group/user modes. The user name and the group name shall be unique. One user shall be included in only one group.
- Currently logged in user cannot change his/her own right.
-

5.6.2.1 Username

In this interface user may enable anonymity login, add/remove user and modify user name. See Figure 5-71.

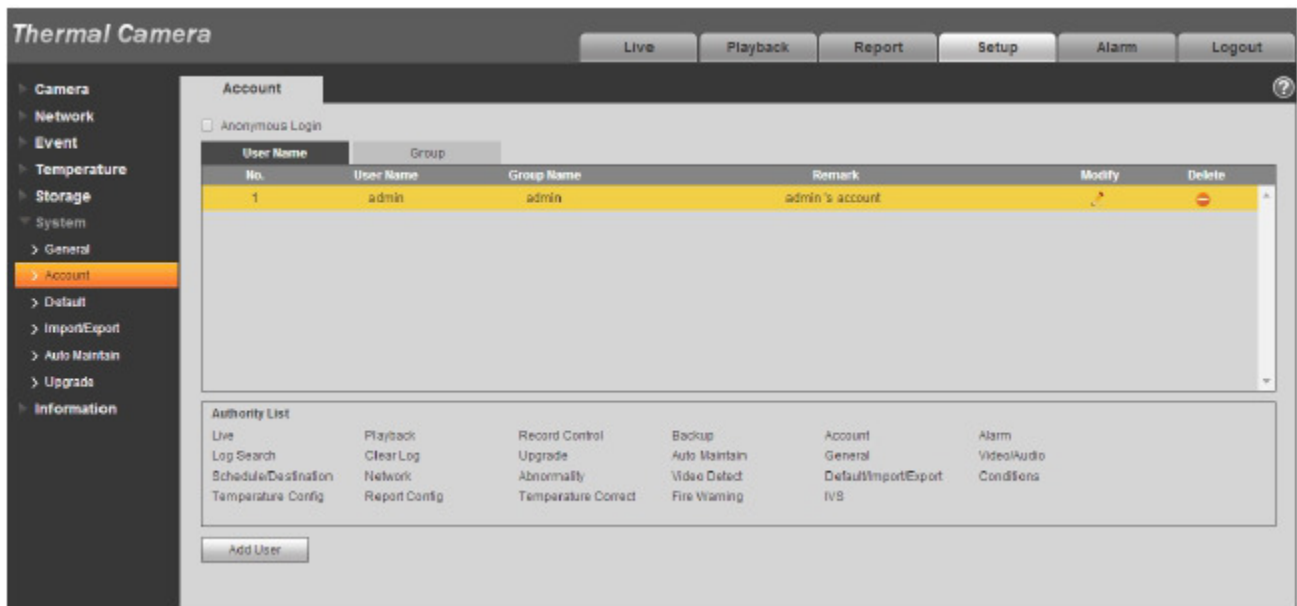

Figure 5-71

Enable anonymity login: Enable anonymity login, and input IP. No username or password is required, user may log in by anonymity (with limited rights). User may click logout to end user session.

Add user: It is to add a name to group and set the user rights. See Figure 5-72

There are four default users: admin/888888/666666 and hidden user “default”. Except user 6666, other users have administrator right. The user 666666 can only have the monitor rights,.

Hidden user “default” is for system interior use only and cannot be deleted. When there is no login user, hidden user “default” automatically login. User may set some rights such as monitor for this user so that user may view some channel view without login.

Here user may input the user name and password and then select one group for current user.

Please note the user rights shall not exceed the group right setup.

For convenient setup, please make sure the general user has the lower rights setup than the admin.

The image shows a software dialog box titled "Add User". It contains the following elements:

- User Name:** A text input field.
- Password:** A password input field with a small icon to toggle visibility.
- Password Strength:** Three radio button options: "Weak", "Middle", and "Strong".
- Confirm Password:** A password input field with a small icon to toggle visibility.
- Group:** A dropdown menu currently showing "admin".
- Remark:** A text input field.
- Authority List:** A list of checkboxes with the following items: "All", "Live", "Playback", "Record Control", and "Backup". All checkboxes are currently checked.
- Buttons:** "Save" and "Cancel" buttons at the bottom.

Figure 5-72

Modify user

It is to modify the user property, belonging group, password and rights. See Figure 5-73.

Modify password

It is to modify the user password. User need to input the old password and then input the new password twice to confirm the new setup. Please click the OK button to save.

Please note, the password ranges from 0-digit to 32-digit. It shall include the number and letter only. For the user who has the account rights, he can modify the password of other users.

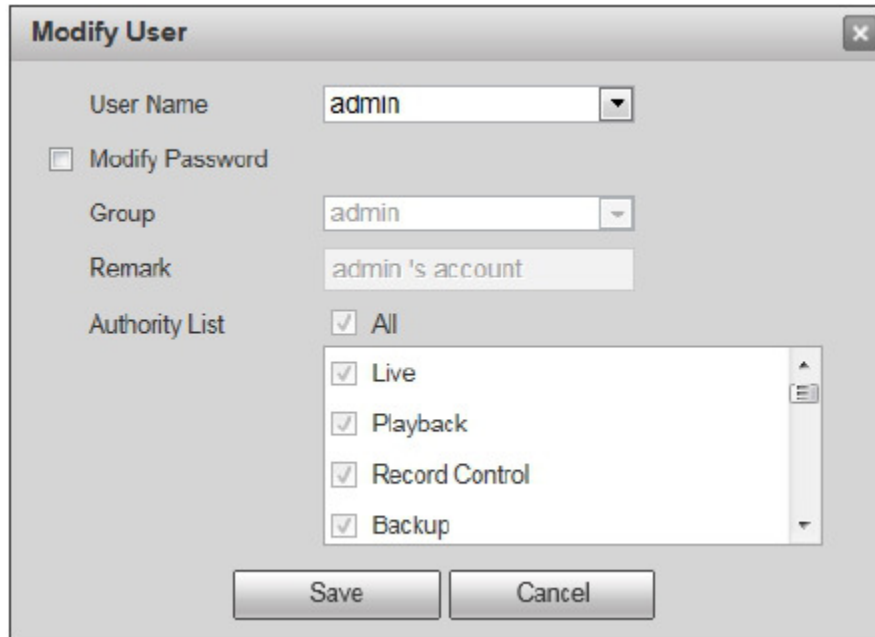

Figure 5-73

5.6.2.2 Group

The group management interface can add/remove group, modify group password and etc. The interface is shown as in Figure 5-73.

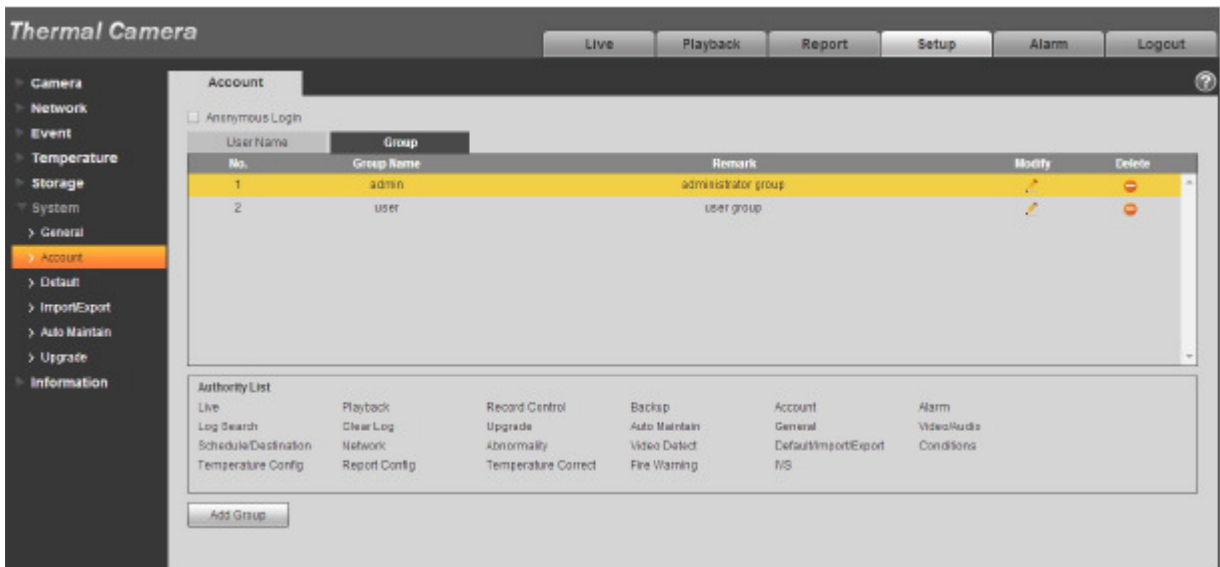

Figure 5-73

Add group: It is to add group and set its corresponding rights. See Figure 5-74.
Please input the group name and then check the box to select the corresponding rights. It includes: preview, playback, record control, PTZ control and etc.

The 'Add Group' dialog box contains the following elements:

- Group:** An empty text input field.
- Remark:** An empty text input field.
- Authority List:** A list box with the following items and checkboxes:
 - All
 - Live
 - Playback
 - Record Control
 - Backup
- Buttons:** 'Save' and 'Cancel' buttons at the bottom.

Figure 5-74

Modify group

Click the modify group button, user may see an interface is shown as in Figure 5-75.
Here user may modify group information such as remarks and rights.

The 'Modify Group' dialog box contains the following elements:

- Group:** A dropdown menu with 'admin' selected.
- Remark:** A text input field containing 'administrator group'.
- Authority List:** A list box with the following items and checkboxes:
 - All
 - Live
 - Playback
 - Record Control
 - Backup
- Buttons:** 'Save' and 'Cancel' buttons at the bottom.

Figure 5-75

5.6.3 Default

The default setup interface is shown as in Figure 5-76.

Please note system cannot restore some information such as network IP address.

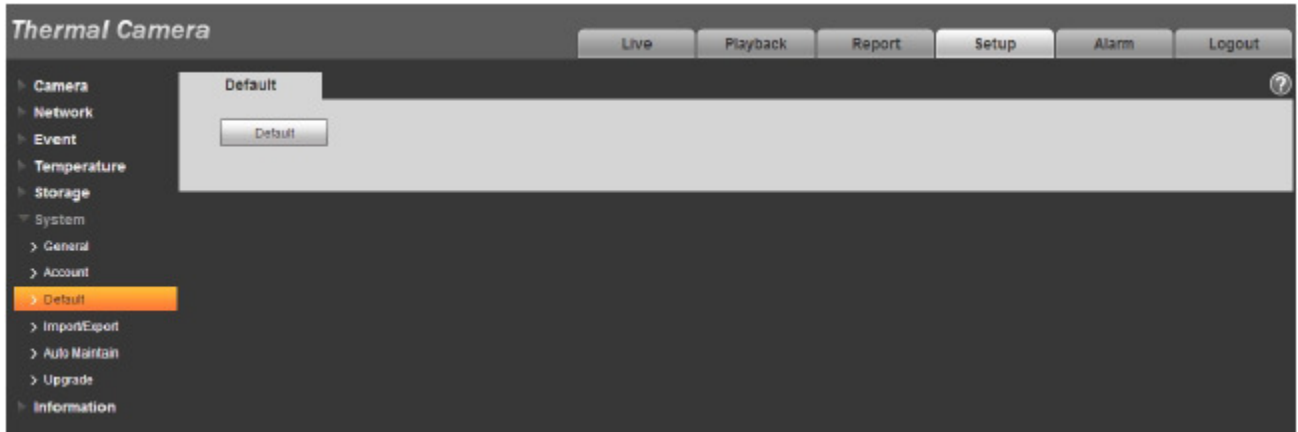

Figure 5-76

5.6.4 Import/Export

The interface is shown as in Figure 5-77.

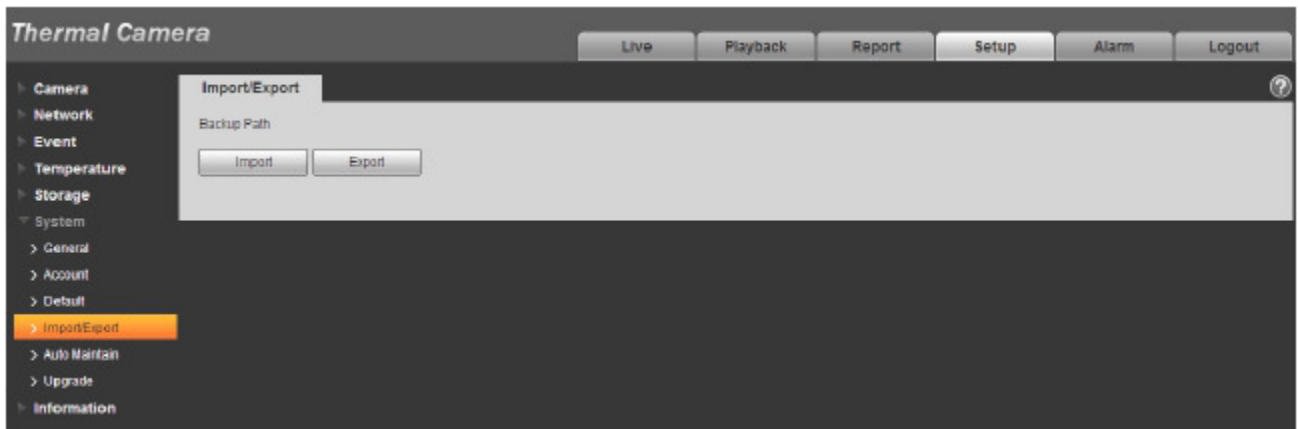

Figure 5-77

Please refer to the following sheet for detailed information.

Parameter	Function
Import	It is to import the local setup files to the system.
Export	It is to export the corresponding system setup to user local PC.

5.6.5 Auto Maintenance

The auto maintenance interface is shown as in Figure 5-78.

Here user may select auto reboot and auto delete old files interval from the dropdown list.
 If user wants to use the auto delete old files function, user need to set the file period.

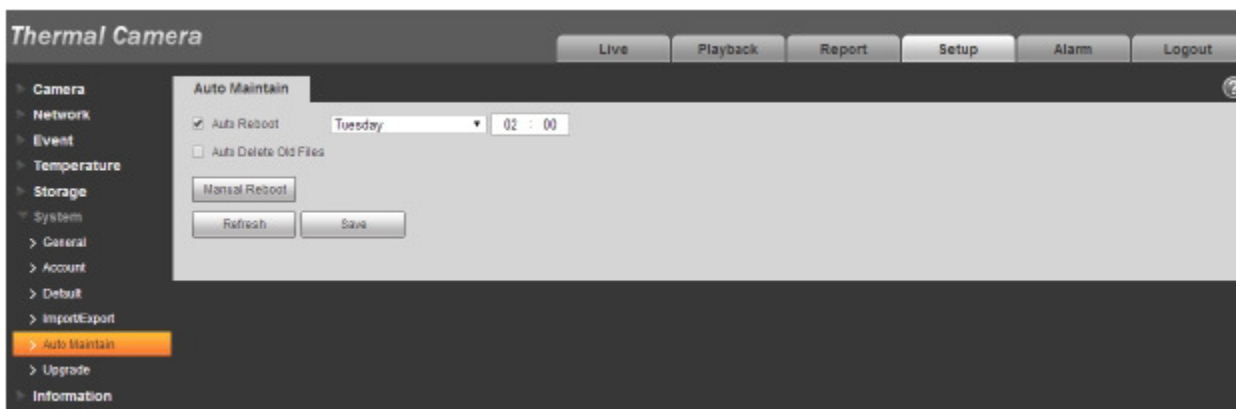

Figure 5-78

Parameter	Function
Auto Reboot	Check it and set auto reboot time.
Auto Delete Old Files	Check it and set period within 1~31 days.

5.6.6 Upgrade

The upgrade interface is shown as in Figure 5-79.

Please select the upgrade file (file extension is “.bin”) and then click the update button to begin firmware update.

Important

Improper upgrade program may result in device malfunction!

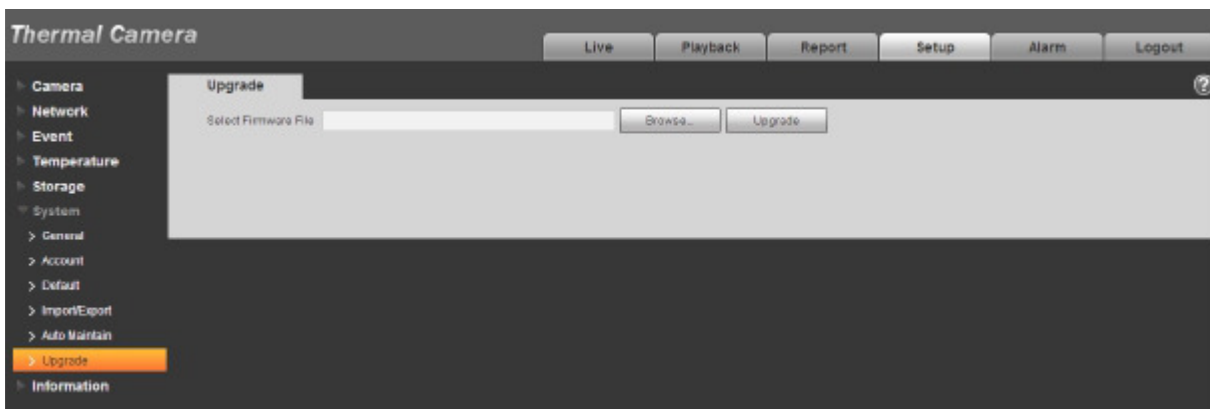

Figure 5-79

5.7 Information

5.7.1 Version

The version interface is shown as in Figure 5-80.

Here user may view system hardware features, software version, release date and etc. Please note the following information is for reference only.

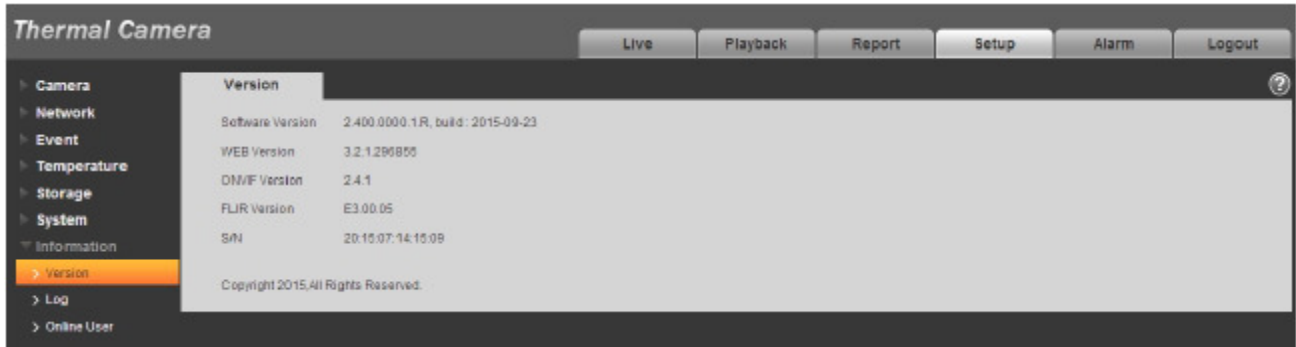

Figure 5-80

5.7.2 Log

Here user may view system log. See Figure 5-81.

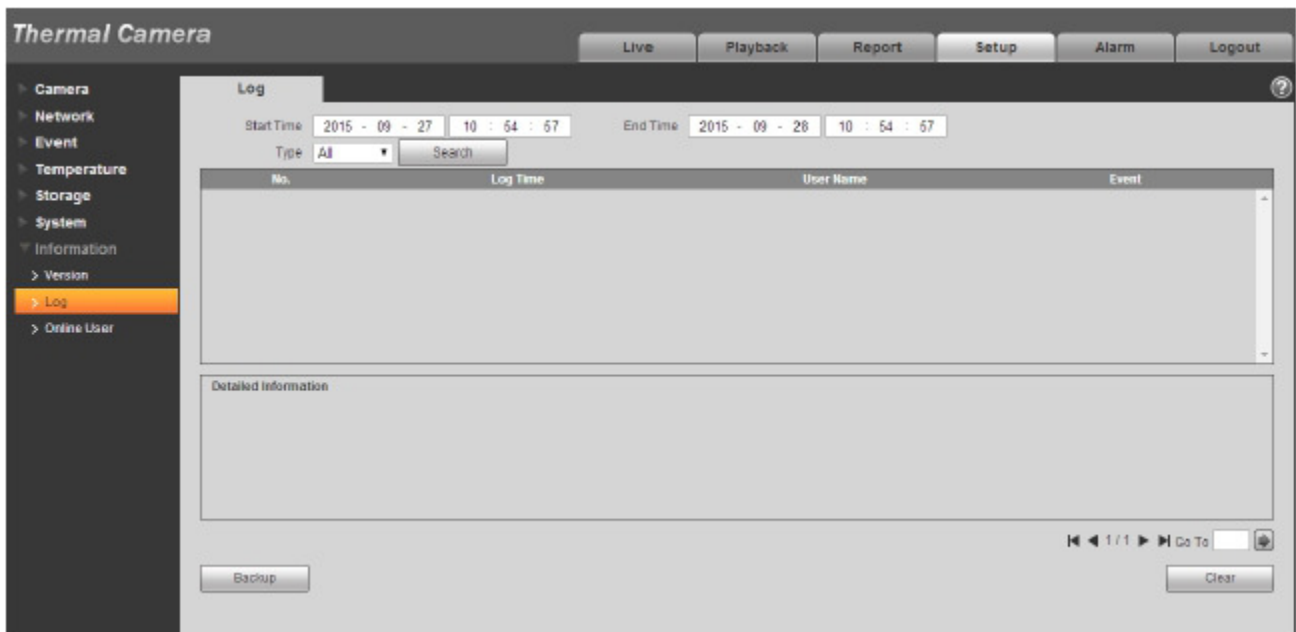

Figure 5-81

Please refer to the following sheet for log parameter information.

Parameter	Function
Start time	Set the start time of the requested log. (The earliest time is 2000/1/1)
End time	Set the end time of the requested log. (The latest time is 2037/12/31)
Type	Log type.
Search	User may select log type from the drop down list and then click search button to view the list. User may click the stop button to terminate current search operation.
Log information	User may select one item to view the detailed information.
Clear	User may click this button to delete all displayed log files. Please note system does not support clear by type.
Backup	User may click this button to backup log files to current PC.

5.7.3 Online User

The online user interface is shown as in Figure 5-82.

Here user may view current online user, group name, IP address and login time.

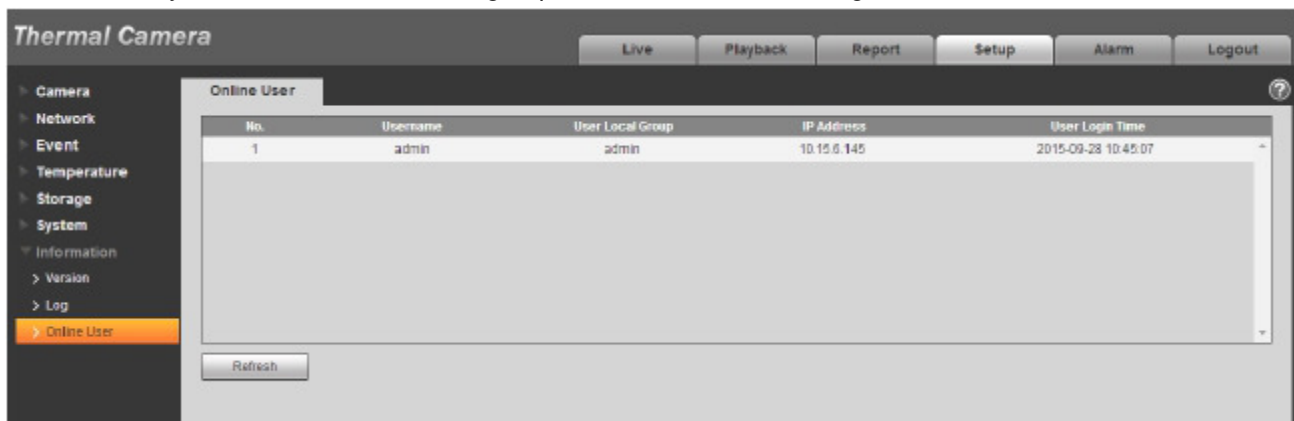

Figure 5-82

6 Alarm

Please note some series product does not support this function.

Click alarm function, user may see an interface is shown as in Figure 6-1.

Here user may set device alarm type and alarm sound setup.

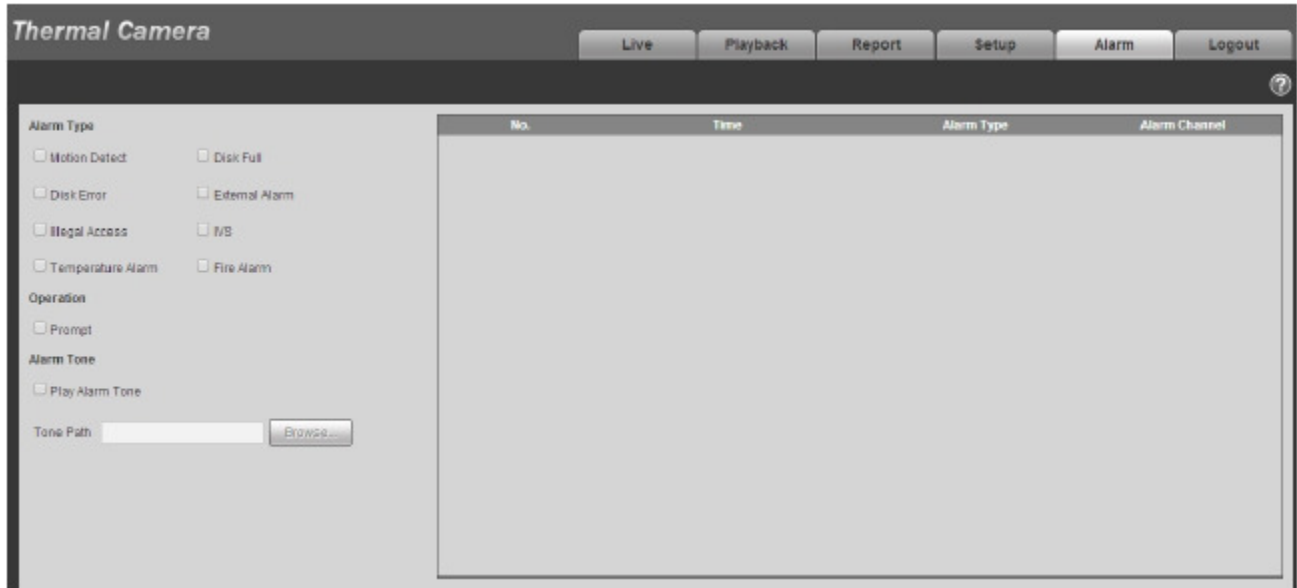

Figure 6-1

Please refer to the following sheet for detailed information.

Type	Parameter	Function
Alarm type	Motion detection	System alarms when motion detection alarm occurs,
	Disk full	System alarms when disk is full.
	HDD malfunction	System generates an alarm when HDD is malfunction.
	External alarm	Alarm input device sends out alarm.
	Unauthorized Access	System alarms when there is unauthorized access.
	IVS	Check it, and the system generates alarm when it meets the condition of IVS. Note: only some models support the function.
	Temperature Alarm	Check it, and the system generates alarm when the temperature meets some certain threshold. Note: only some models support the function.
	Fire Alarm	Check it, and the system generates alarm when it meets the threshold of fire alarm. Note: only some models support the function.

Type	Parameter	Function
Operation	Prompt	When alarm is triggered, there will be s In main menu of alarm interface and system automatically records alarm info. The icon disappears when user click on alarm menu bar. Note: If alarm interface is displayed, when alarm is triggered, there will be no image prompt, but alarm record will be in list on the right.
Alarm audio	Audio	When alarm occurs, system auto generates alarm audio. The audio supports customized setup.
	Path	Here user may specify alarm sound file.

7 Log out

Click log out button, system goes back to log in interface. See Figure 7-1.

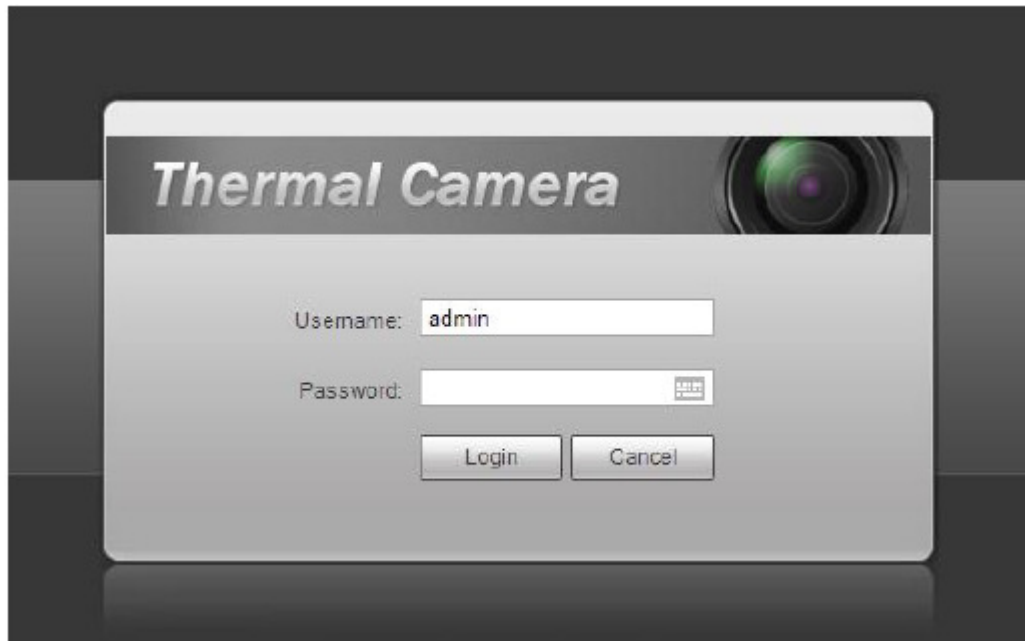

Figure 7-1

Note:

- **This manual is for reference only. Slight difference may be found in user interface.**
- **All the designs and software here are subject to change without prior written notice.**
- **All trademarks and registered trademarks mentioned are the properties of their respective owners.**
- **If there is any uncertainty or controversy, please refer to the final explanation of us.**
- **Please visit our website for more information.**

For Technical support write to

support@dantesecurity.net

1.Add Device

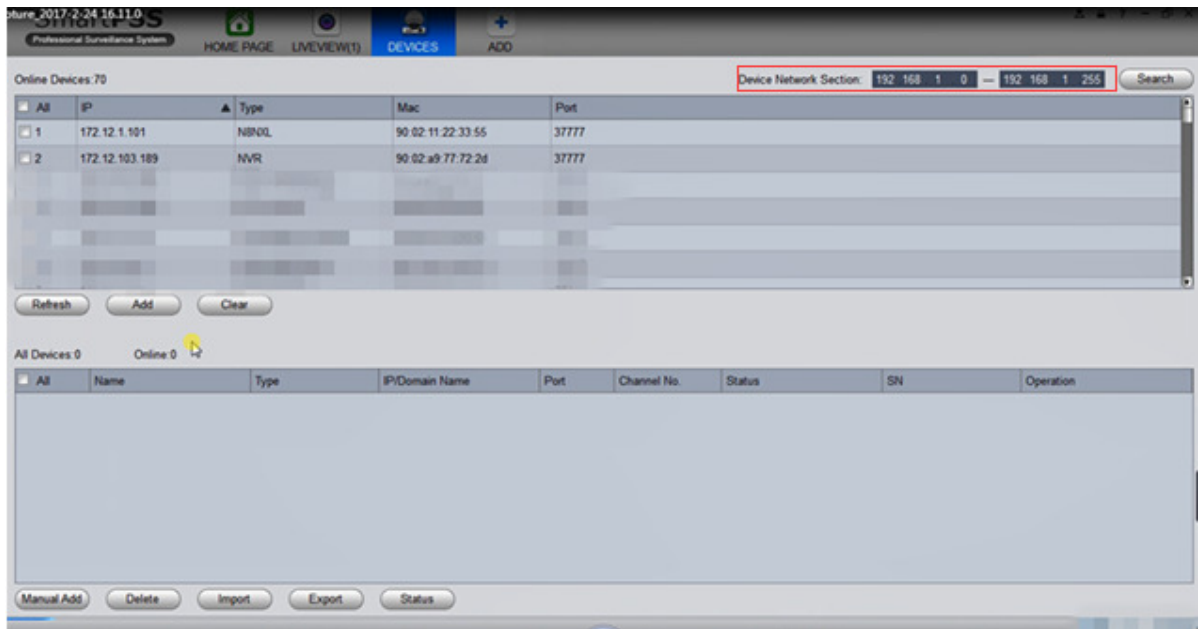

Step1 In the "DEVICES" interface, enter the starting IP address and the end IP address, click "Search", The system shows the search results.

Step2 Select the device you want to add.

Step3 Click "Add".

The device is displayed in the "All Device" list and is automatically logged in when the device is added, as shown in the picture below.

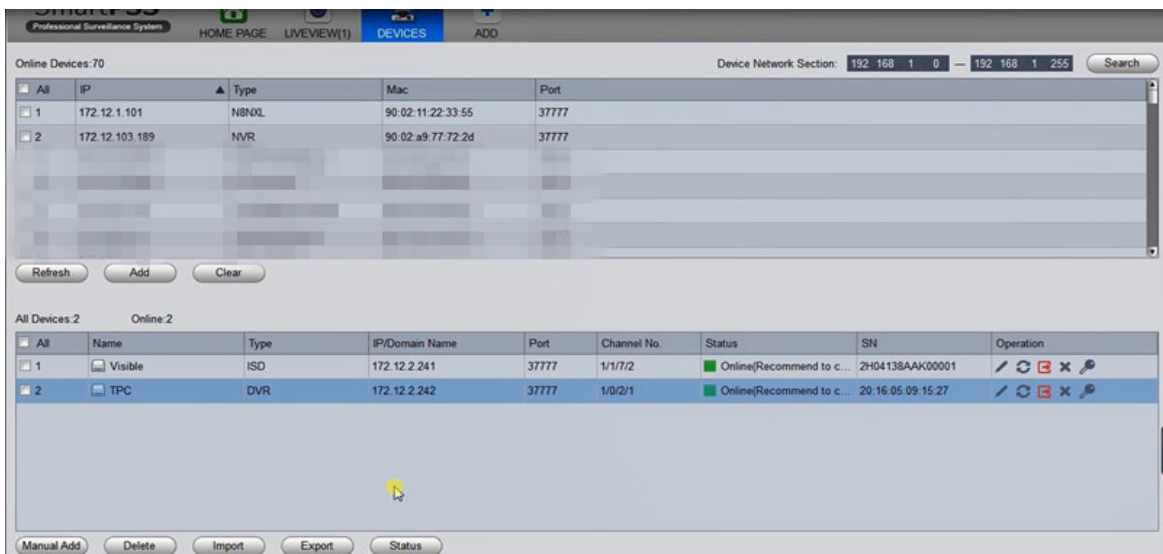

2. Calibrate TPC and PTZ Dome



Step 1 Click [HOME PAGE](#), and select [LIVEVIEW](#). The system displays the Liveview interface, as shown in the picture below.

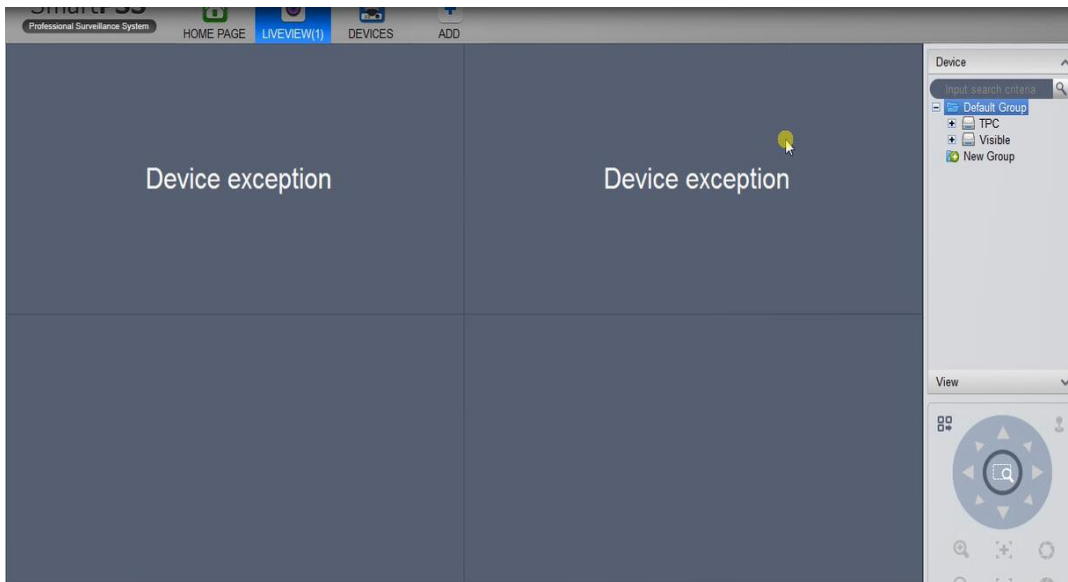

Click the devices that we added in the device list, the image is displayed in the Liveview interface. As shown in the two pictures below.

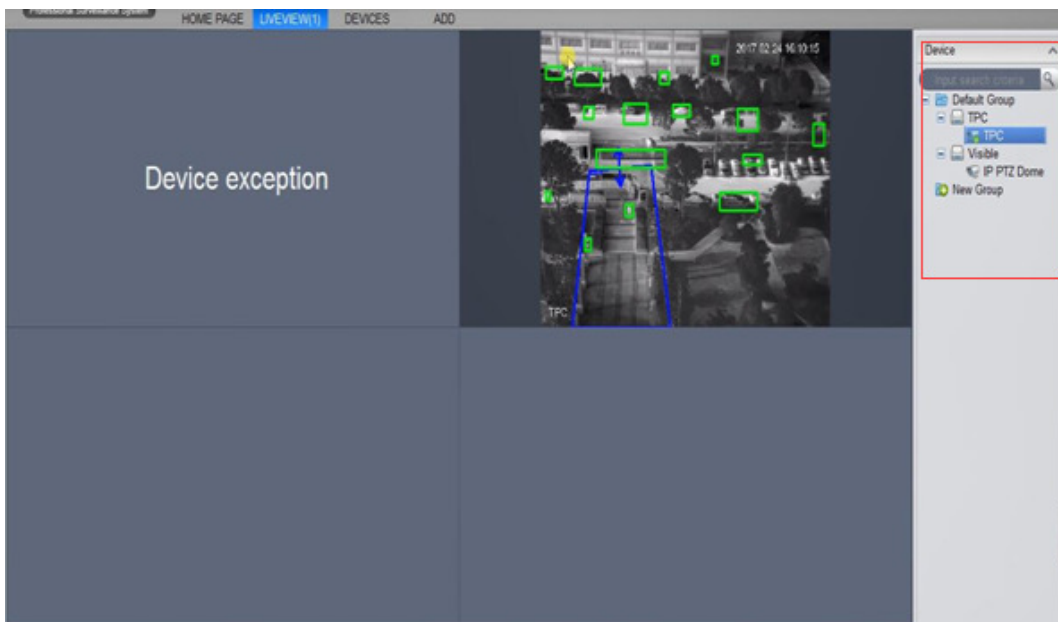

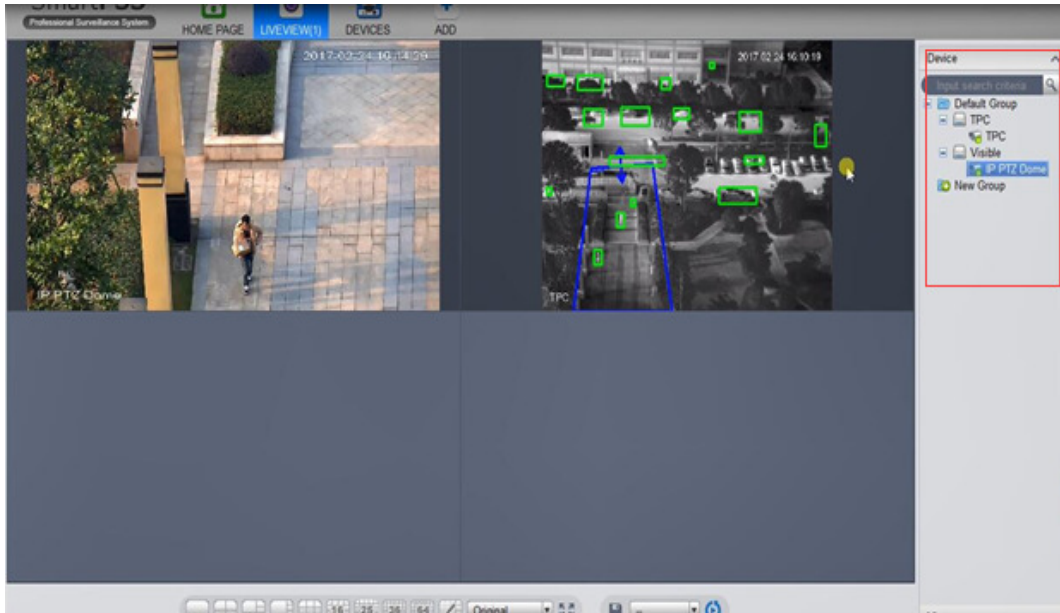

Step 2 Select the TPC in the devices list, right click to select "Smart Track Config", as shown in the picture below.

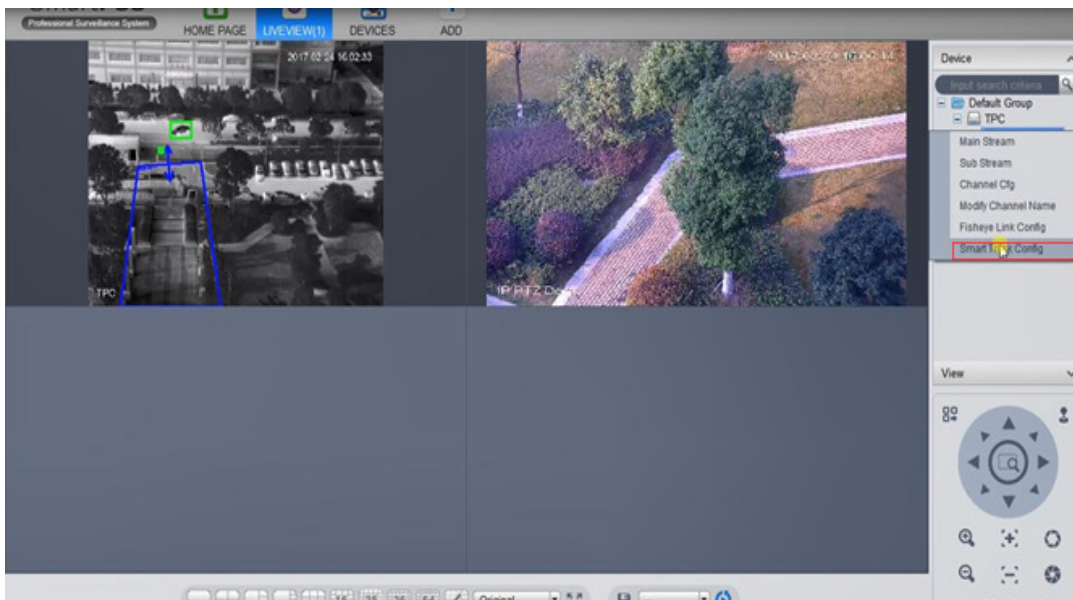

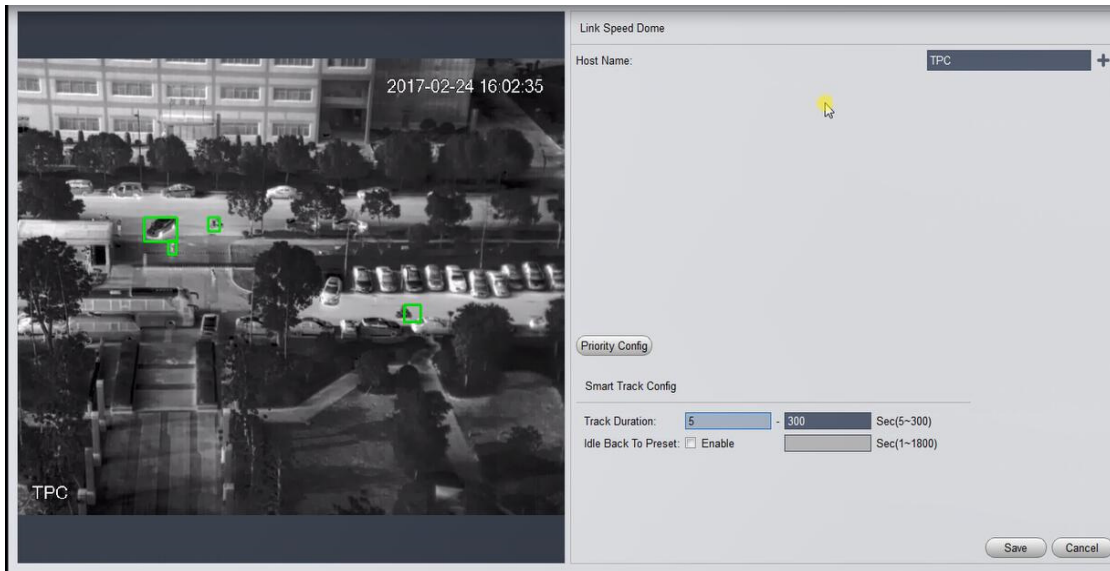

The system displays the " Smart Track Config " interface, as shown in the picture below.

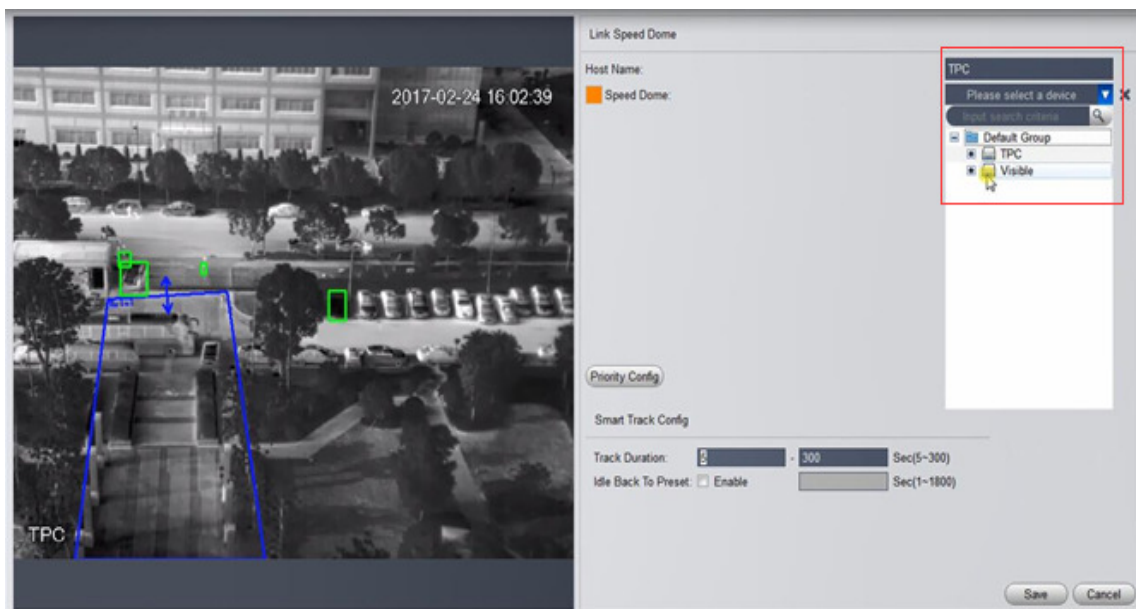

Step 3 Connect with PTZ Dome, as shown in the picture below.



1. In the "Host Name" region, Click .
2. Click , select PTZ Dome in the drop down box.
3. Set the Smart Track Config, refer to the table below for detailed parameter description.

Description of parameters of Smart Track Config

Parameter	Description
Track Duration	Supports setting the upper and lower limits of duration. If the target of track is two or more in the screen, the maximum length of the tracking is the lower limit of the setting duration; If there is only one target in the screen, the maximum length of tracking is the upper limit of the setting duration.
Idle Back To Preset	Select "Enable", after enabling the Idle Back To Preset function, when there is no target that reach the setting duration, the picture of PTZ Dome go back to the Preset point.

4. Click "Save".

Then the system displays interface of the calibration of Smart Track, as shown in the picture below.

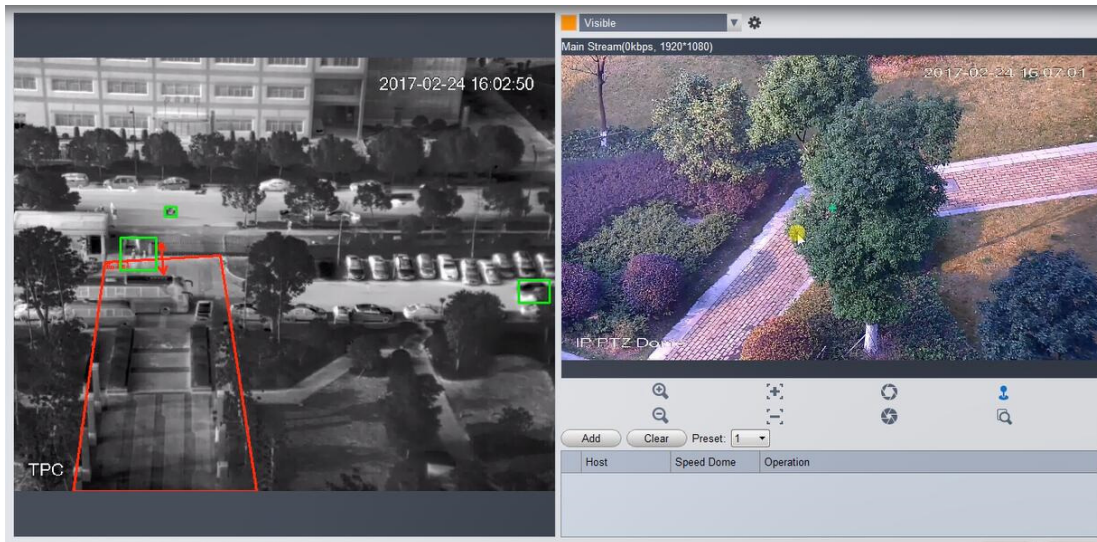

Step 4 Calibrate TPC and PTZ Dome, as shown in the picture below

Note: Configure the mark pair at least 4 pairs, maximum 8 pairs, 4 pairs is recommended.

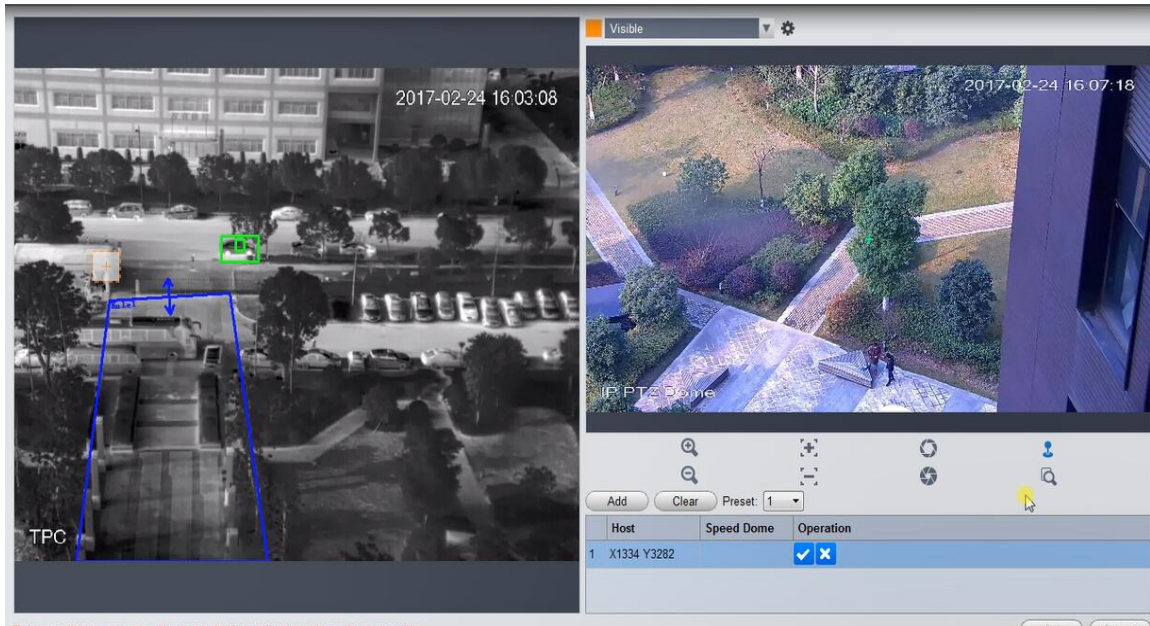

1. Click "Add".
A cross mark appears on the screen of TPC, a center cross mark appears on the screen of PTZ Dome, at the same time produce a record.
2. Drag the cross mark to the right position on the screen of TPC.
3. Turn the PTZ Dome, make the position of cross marks on the screen of TPC and PTZ Dome coincide.

Note: We recommend to click , enlarge the screen of PTZ Dome to the maximum, and then calibrate.

4. Click , save the tag information.
5. Repeat action1~4, finish the configuration of the rest of the mark pairs.
6. After the configuration of all the mark pairs, click "OK", save the information of configuration.

Step 5 Works

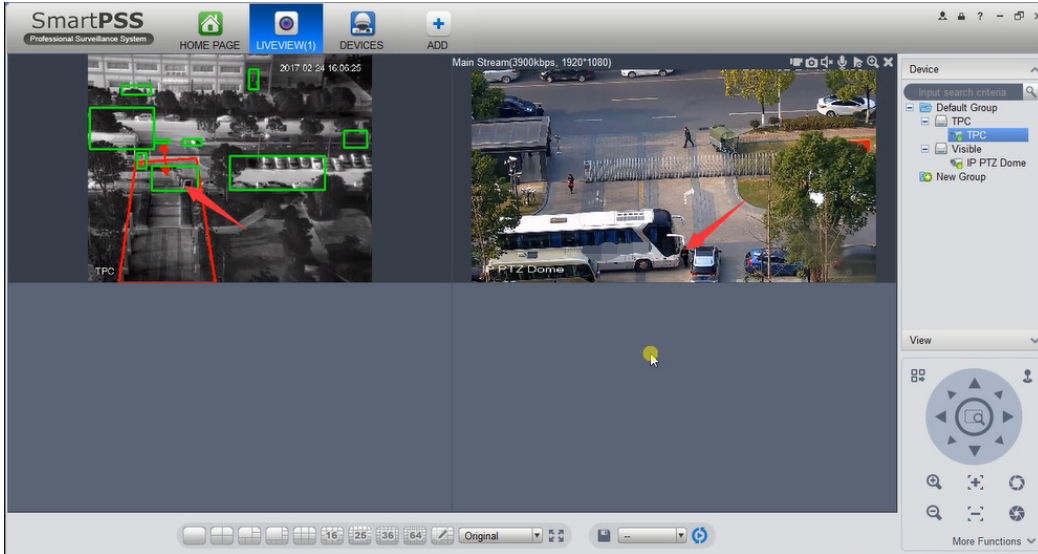

The person (see red arrow) enters the zone that thermal drew, the thermal camera recognizes, marks him as a green square, the green square enters the red square, it will trigger the PTZ auto-tracking.

